HP 85330A Multiple Channel Controller

Operating, Programming,
and Service Manual

HP part number: 85330-90019
Printed in USA
November 1999

Revision 3.0

Notice

The information contained in this document is subject to change without notice.

Hewlett-Packard makes no warranty of any kind with regard to this material, including, but not limited to, the implied warranties of merchantability and fitness for a particular purpose. Hewlett-Packard shall not be liable for errors contained herein or for incidental or consequential damages in connection with the furnishing, performance, or use of this material.

Hewlett-Packard assumes no responsibility for the use or reliability of its software on equipment that is not furnished by Hewlett-Packard.

This document contains proprietary information which is protected by copyright. All rights are reserved. No part of this document may be photocopied, reproduced, or translated to another language without prior written consent of Hewlett-Packard Company.

Restricted Rights Legend

Use, duplication, or disclosure by the U.S. Government is subject to restrictions as set forth in subparagraph (c)(1)(ii) of the Rights in Technical Data and Computer Software clause at DFARS 252.227-7013 for DOD agencies, and subparagraphs (c)(1) and (c)(2) of the Commercial Computer Software Restricted Rights clause at FAR 52.227-19 for other agencies.

Hewlett-Packard Company
Santa Rosa Systems Division
1400 Fountaingrove Parkway
Santa Rosa, CA 95403-1799, U.S.A.

Edition	Date	Serial Prefix	Firmware	Contribution
Edition 1	May 1993	3223A	A.02.20	First Release
Edition 2	February 1994	3223A	A.02.31	Added Multiple Controller Control
Edition 3	November 1999	US3932	A.03.00	Downloadable Driver Disk Revision

© Copyright Hewlett-Packard Company 1997,1999

What You'll Find in This Manual...

- Your Specific System**
- If you bought a preconfigured system, HP supplied documentation that is specific for your system. This empty tab section gives you a place to keep this documentation.
- Chapter 1**
- Installation - Shows how a standard HP 85330A system is installed. If you purchased a preconfigured system, HP has provided documentation that contains installation information for your specific system. Use the documentation for your special system *instead* of the information in this chapter.
- Chapter 2**
- Performance Verification - Explains how to verify that the HP 85330A system is operating properly.
- Chapter 3**
- Operator's Check - This is a quick check of the system to make sure it is operating properly.
- Chapter 4**
- General Information - Describes a typical system, and includes information on:
 - Supplied items
 - Features
 - HP 85330A connectors
 - Accessories
 - Specifications
 - Environmental Characteristics
 - Compatible instruments
- Chapter 5**
- Manual Operation - Describes functions that can be performed manually using the multiple channel controllers front panel softkeys.
- Chapter 6**
- Programming - Describes the HP 85330A programming fundamentals with examples.
- Chapter 7**
- Remote Programming Command Reference - A dictionary of the HP 85330As programming commands.
- Chapter 8**
- In Case of Difficulty - How to solve common system problems.

Chapter 9 • Service - Explains how to determine if the HP 85330A specific control cards are working. This chapter does not explain how to troubleshoot the VXI mainframe, which has its own service documentaiton.pendix A

Appendix A • Glossary of Terms - This glossary defines special terminology associated with this system. Words shown in **bold** text are defined in the glossary.

Warranty

Certification

Hewlett-Packard Company certifies that this product met its published specifications at the time of shipment from the factory. Hewlett-Packard further certifies that its calibration measurements are traceable to the United States National Institute of Standards and Technology (NIST, formerly NBS), to the extent allowed by the Institute's calibration facility, and to the calibration facilities of other International Standards Organization members.

Warranty

This Hewlett-Packard system product is warranted against defects in materials and workmanship for a period corresponding to the individual warranty periods of its component products. Instruments are warranted for a period of one year. During the warranty period, Hewlett-Packard Company will, at its option, either repair or replace products that prove to be defective.

Warranty service for products installed by HP and certain other products designated by HP will be performed at Buyer's facility at no charge within HP service travel areas. Outside HP service travel areas, warranty service will be performed at Buyer's facility only upon HP's prior agreement and Buyer shall pay HP's round trip travel expenses. In all other areas, products must be returned to a service facility designated by HP.

For products returned to HP for warranty service, Buyer shall prepay shipping charges to HP and HP shall pay shipping charges to return the product to Buyer. However, Buyer shall pay all shipping charges, duties, and taxes for products returned to HP from another country.

HP warrants that its software and firmware designated by HP for use with an instrument will execute its programming instructions when properly installed on that instrument. HP does not warrant that the operation of the instrument, or software, or firmware will be uninterrupted or error free.

LIMITATION OF WARRANTY. The foregoing warranty shall not apply to defects resulting from improper or inadequate maintenance by Buyer, Buyer-supplied software or interfacing, unauthorized modification or misuse, operation outside of the environmental specifications for the product, or improper site preparation or maintenance.

NO OTHER WARRANTY IS EXPRESSED OR IMPLIED. HP SPECIFICALLY DISCLAIMS THE IMPLIED WARRANTIES OR MERCHANTABILITY AND FITNESS FOR A PARTICULAR PURPOSE.

EXCLUSIVE REMEDIES. THE REMEDIES PROVIDED HEREIN ARE BUYER'S SOLE AND EXCLUSIVE REMEDIES. HP SHALL NOT BE

LIABLE FOR ANY DIRECT, INDIRECT, SPECIAL, INCIDENTAL, OR CONSEQUENTIAL DAMAGES, WHETHER BASED ON CONTRACT, TORT, OR ANY OTHER LEGAL THEORY.

Assistance

Product maintenance agreements and other customer assistance agreements are available for Hewlett-Packard products.

For assistance, call your local Hewlett-Packard Sales and Service Office (refer to “Service and Support” on page vii).

Service and Support

Any adjustment, maintenance, or repair of this product must be performed by qualified personnel. Contact your customer engineer through your local HP Service Center. You can find a list of HP Service Centers on the web at <http://www.hp.com/go/tmdir>.

If you do not have access to the Internet, one of these HP centers can direct you to your nearest HP representative:

United States:	Hewlett-Packard Company Test and Measurement Call Center PO Box 4026 Englewood, CO 80155-4026 (800) 452 4844 (toll-free in US)
Canada:	Hewlett-Packard Canada Ltd. 5150 Spectrum Way Mississauga, Ontario L4W 5G1 (905) 206 4725
Europe:	Hewlett-Packard European Marketing Centre Postbox 999 1180 AZ Amstelveen The Netherlands (31 20) 547 9900
Japan:	Hewlett-Packard Ltd. Measurement Assistance Center 9-1, Takakura-Cho, Hachioji-Shi Tokyo 192, Japan (81) 426 56 7832 (81) 426 56 7840 (FAX)
Latin America:	Hewlett-Packard Latin American Region Headquarters 5200 Blue Lagoon Drive, 9th Floor Miami, Florida 33126, U.S.A. (305) 267 4245, (305) 267-4220 (305) 267 4288 (FAX)
Australia/New Zealand:	Hewlett-Packard Australia Ltd. 31-41 Joseph Street Blackburn, Victoria 3130 Australia 1 800 629 485 (Australia) 0800 738 378 (New Zealand) (61 3) 9210 5489 (FAX)
Asia-Pacific:	Hewlett-Packard Asia Pacific Ltd. 17-21/F Shell Tower, Times Square 1 Matheson Street, Causeway Bay Hong Kong (852) 2599 7777 (852) 2506 9285 (FAX)

Safety and Regulatory Information

Review this product and related documentation to familiarize yourself with safety markings and instructions before you operate the instrument. This product has been designed and tested in accordance with international standards.









WARNING

The **WARNING** notice denotes a hazard. It calls attention to a procedure, practice, or the like, that, if not correctly performed or adhered to, could result in personal injury. Do not proceed beyond a **WARNING** notice until the indicated conditions are fully understood and met.

CAUTION

The **CAUTION** notice denotes a hazard. It calls attention to an operating procedure, practice, or the like, which, if not correctly performed or adhered to, could result in damage to the product or loss of important data. Do not proceed beyond a **CAUTION** notice until the indicated conditions are fully understood and met.

Instrument Markings

	When you see this symbol on your instrument, you should refer to the instrument's instruction manual for important information.
	This symbol indicates hazardous voltages.
	The laser radiation symbol is marked on products that have a laser output.
	This symbol indicates that the instrument requires alternating current (ac) input.
	The CE mark is a registered trademark of the European Community. If it is accompanied by a year, it indicates the year the design was proven.
	The CSA mark is a registered trademark of the Canadian Standards Association.
1SM1-A	This text indicates that the instrument is an Industrial Scientific and Medical Group 1 Class A product (CISPER 11, Clause 4).
	This symbol indicates that the power line switch is ON.
	This symbol indicates that the power line switch is OFF or in STANDBY position.

 **Safety Earth
Ground**

This is a Safety Class I product (provided with a protective earthing terminal). An uninterruptible safety earth ground must be provided from the main power source to the product input wiring terminals, power cord, or supplied power cord set. Whenever it is likely that the protection has been impaired, the product must be made inoperative and secured against any unintended operation.

**Before Applying
Power**

Verify that the product is configured to match the available main power source as described in the input power configuration instructions in this manual. If this product is to be powered by autotransformer, make sure the common terminal is connected to the neutral (grounded) side of the ac power supply.

WARNING

No operator serviceable parts inside. Refer servicing to qualified personnel. To prevent electrical shock do not remove covers.

WARNING

For continued protection against fire hazard, replace line fuse only with the same type and ratings (type nA/nV). The use of other fuses or materials is prohibited.

WARNING

To prevent electrical shock, disconnect the HP 85330A from mains before cleaning. Use a dry cloth or one slightly dampened with water to clean the external case parts. Do not attempt to clean internally.

WARNING

If this product is not used as specified, the protection provided by the equipment could be impaired. This product must be used in a normal condition (in which all means for protection are intact).

CAUTION

Always use the three-prong ac power cord supplied with this product. Failure to ensure adequate earth grounding by not using this cord may cause product damage.

CAUTION

Install the instrument according to the enclosure protection provided. This instrument does not protect against the ingress of water.

This instrument protects against finger access to hazardous parts with the enclosure.

Manufacturers Declaration

This is to certify that this product meets the radio frequency interference requirements of Directive FTZ 1046/1984. The German Bundespost has been notified that this equipment was put into circulation and has been granted the right to check the product type for compliance with these requirements.

This product has been designed and tested in accordance with IEC Publication 1010, Safety Requirements for Electronic Measuring Apparatus, and has been supplied in a safe condition. The instruction documentation contains information and warnings which must be followed by the user to ensure safe operation and to maintain the product in a safe condition.

NOTE

If test and measurement equipment is operated with unshielded cables and/or used for measurements on open set-ups, the user must ensure that under these operating conditions, the radio frequency interference limits are met at the border of his premises.

Hiermit wird bescheinigt, dass dieses Gerät/System in Übereinstimmung mit den Bestimmungen von Postverfügung 1046/84 funkentstört ist.

Der Deutschen Bundespost wurde das Inverkehrbringen dieses Gerät/Systems angezeigt und die Berechtigung zur Überprüfung der Serie auf Einhaltung der Bestimmungen eingeräumt.

Zustuzinformatiön für Mess- und Testgeräte:

Werden Mess- und Testgeräte mit ungeschirmten Kabeln und/oder in offenen Messaufbauten verwendet, so ist vom Betreiber sicherzustellen, dass die Funk-Entstörbestimmungen unter Betriebsbedingungen an seiner Grundstücksgrenze eingehalten werden.

Sound Emissions

This is to declare that this product is in conformance with the German Regulation on Noise Declaration for Machines (Laermangabe nach der maschinenlaermverordnung -3. GSGV Deutschland).

Acoustic Noise Emission	Geraeuschemission
LpA < 70 dB	LpA < 70 dB
Operator Position	am Arbeitsplatz
Normal Position	normaler Betrieb
per ISO 7779	nach DIN 45635 t. 19

DECLARATION OF CONFORMITY

According to ISO/IEC Guide 22 and EN 45014

Manufacturer's Name: Hewlett-Packard Co.

Manufacturer's Address: 1400 Fountaingrove Parkway
Santa Rosa, CA 95403-1799
USA

Declares that the product:

Product Name: Multiple Channel Controller

Model Number: HP 85330A

Product Options: This declaration covers all options of the above product.

Conforms to the following product specifications:

Safety: IEC 61010-1:1990 / EN 61010-1:1993
CAN/CSA-C22.2 No. 1010.1-92

EMC: CISPR 11:1990/EN 55011:1991 Group 1, Class A
IEC 801-2:1984/EN 50082-1:1992 4 kV CD, 8 kV AD
IEC 801-3:1984/EN 50082-1:1992 3 V/m, 27-500 MHz
IEC 801-4:1988/EN 50082-1:1992 0.5 kV sig. lines, 1 kV power lines

Supplementary Information:

The product herewith complies with the requirements of the Low Voltage Directive 73/23/EEC and the EMC Directive 89/336/EEC and carries the CE-marking accordingly.

The controller was tested with HP 85331A and HP 85332A switches.

Santa Rosa, CA, USA 12 July 1999



Greg Pfeiffer/Quality Engineering Manager

European Contact: Your local Hewlett-Packard Sales and Service Office or Hewlett-Packard GmbH Department HQ-TRE, Herreneberger Strasse 130, D71034 Boblingen, Germany (FAX +49-7031-14-3143)

Typeface Conventions

- Italics*
 - Used to emphasize important information:
Use this software *only* with the HP85330A system.
 - Used for the title of a publication:
Refer to the *HP 85330A System-Level User's Guide*.
 - Used to indicate a variable:
Type `LOAD BIN filename`.
- Instrument Display**
 - Used to show on-screen prompts and messages that you will see on the display of an instrument:
The HP xxxxxX will display the message `CAL1 SAVED`.
- [Keycap]**
 - Used for labeled keys on the front panel of an instrument or on a computer keyboard:
Press `[Return]`.
- {Softkey}**
 - Used for simulated keys that appear on an instrument display:
Press `{Prior Menu}`.
- User Entry**
 - Used to indicate text that you will enter using the computer keyboard; text shown in this typeface must be typed *exactly* as printed:
Type `LOAD PARMFILE`
 - Used for examples of programming code:
`#endif // ifndef NO_CLASS`
- Path Name*
 - Used for a subdirectory name or file path:
Edit the file `usr/local/bin/sample.txt`
- Computer Display**
 - Used to show messages, prompts, and window labels that appear on a computer monitor:
The `Edit Parameters` window will appear on the screen.
 - Used for menus, lists, dialog boxes, and button boxes on a computer monitor from which you make selections using the mouse or keyboard:
Double-click `EXIT` to quit the program.

Contents

1. Installation

Installation at a Glance	1-1
Preparing the Main Antenna Measurement System	1-2
Installing the HP 85330A Multiple Channel Controller	1-2
Choosing the Proper Configuration	1-2
<i>Figure 1-1. Flow Chart for Choosing the Correct Installation</i>	1-3
<i>Figure 1-2. HP 85330A Installation Diagram for HP 8530A Source</i> <i>Control</i>	1-4
<i>Figure 1-3. HP 85330A Installation Diagram for Fast (TTL) Source</i> <i>Control</i>	1-5
Checking Operation of the Multiple Channel Controller	1-6
Loading the Driver from a Personal Computer	1-6
Viewing or Changing the Multiple Channel Controller's HP-IB Address	1-8
Selecting Positive or Negative-Edge Event Triggers	1-9
<i>Figure 1-4. Positive/Negative-Edge EVENT TRIG jumpers</i>	1-10
Installing the Switch Control Units and Switches	1-11
Mounting the SCU and RF Switch	1-11
Switch Control Unit Configuration Switches	1-11
<i>Figure 1-5. SCU and Switch Mounting Diagram</i>	1-12

2. Performance Verification

In this Chapter	2-1
Description	2-1
Recommended Equipment	2-2
<i>Table 2-1. Required Equipment</i>	2-2
Performance Verification Test	2-3
Setting Up the Equipment	2-3
HP 85330 System	2-3
<i>Figure 2-1. An Example Performance Verification Setup</i>	2-3
Digital Oscilloscope	2-4
Network Analyzer	2-5
Cables	2-5
Calibration	2-5
Save Setup	2-5
Verifying the Multiple Channel Controller	2-6
Turn-On	2-6
Voltage Check	2-6
<i>Table 2-2. Switch Control Unit Voltages</i>	2-6
<i>Figure 2-2. Switch Control Unit Output Connector Voltages</i>	2-7
Inputs/Outputs	2-7

Output Trigger Test	2-7
Pulse Receive and Cycle Test	2-8
Counter Pulse Delay Test	2-9
<i>Figure 2-3. Counter Pulse Delay Test Setup</i>	2-10
<i>Figure 2-4. 15 millisecond Delay Trigger Example</i>	2-10
Measurement Busy Signal and Pulse Width Test	2-11
Verifying the Switch Control Unit	2-12
Verifying the RF Switches	2-13
Switch Setup	2-13
<i>Figure 2-5. RF Switch Test Setup</i>	2-13
RF Performance Tests	2-14
Verifying Remote Ports 1 and 2	2-15
Jumpers	2-15
<i>Figure 2-6. Jumper Assembly</i>	2-15
AUX 1 and AUX 2	2-17
Pulse Test	2-17
Measuring Pulses from AUX 1 or AUX 2	2-17
AUX 1 and AUX 2 Output Voltage Test	2-18
When Finished with All Tests	2-18
3. Operator's Check	
Purpose	3-1
Procedure	3-1
4. General Information	
In This Chapter	4-1
<i>Figure 4-1. HP 85330A System Overview</i>	4-1
Product Description	4-2
In-depth Information	4-2
Manual Operation	4-3
Automated Operation	4-3
Preparing the HP 85330A to Control the System	4-4
Special Systems	4-4
Switch Components	4-4
The Downloadable Driver	4-5
System Interface	4-5
Required Equipment	4-5
Cables	4-5
<i>Table 4-1. HP 85383 Wiring Table</i>	4-6
PIN Switches	4-7
Supplied Equipment and Software	4-8
<i>Table 4-2. Supplied Equipment and Software</i>	4-8
HP 85330A Multiple Channel Controller Characteristics	4-9
Environmental Limits	4-9
<i>Table 4-3. Environmental Conditions for the HP 85330A</i>	4-9
Ventilation Requirements	4-10
Dimensions	4-10
<i>Table 4-4. Size and Dimensions</i>	4-10

Front Panel Features	4-11
Need More Information	4-11
Rear Panel Features	4-12
<i>Figure 4-2. HP 85330A Rear Panel Connectors</i>	4-12
HP 85330A Compatibility	4-15
Compatible Receivers	4-15
Compatible LO Sources	4-15
<i>Table 4-5. Required Options for HP 836xx LO Sources</i>	4-15
Compatible RF Sources	4-15

5. Manual Operation

In This Chapter	5-1
To Use the Front Panel	5-2
About the Softkeys Menus	5-2
Utility Keys	5-2
Softkey Map	5-3
<i>Figure 5-1. HP 85330A Softkey Menu Map</i>	5-3
To View or Change the HP 85330's HP-IB Address	5-4
Viewing HP-IB Address	5-4
Changing the HP-IB Address	5-4
To Close Any Switch In the System	
(to select a channel)	5-5
More about Switch Addresses	5-5
To Change the TTL State of AUX 1 or AUX 2	5-6
To View the Most Recent Error Message	5-7
To View the Revision of the Downloaded Driver	5-8
To View Custom Option Number (If Applicable)	5-9
To Manually Send Trigger Pulses	5-10
To Perform Service Functions	5-10

6. Programming

In This Chapter	6-1
HP-IB Addresses	6-1
Long and Short Command Syntax	6-1
Definition of Terms	6-2
To Choose a Measurement Configuration	6-3
<i>Figure 6-1. Flow Chart for Finding the Correct Configuration</i> ...	6-3
CW Measurement Configuration	6-4
Description	6-4
To Use this Configuration	6-4
Single Source Multiple-Frequency Configuration	6-5
Description	6-5
To Use this Configuration	6-5
Dual Source Multiple-Frequency Measurements	6-7
HP 8530A Control of Sources	6-7
Description	6-7
To Use this Configuration	6-7
Fast Source Control	6-8

Description	6-8
To Use this Configuration	6-8
To Use Direct Control	6-9
Selecting a Channel	6-9
To Use Run-Time Control Mode	6-12
Setup of the HP 85330A Multiple Channel Controller	6-12
Event Triggering	6-12
Number of Frequency Points	6-12
Number of Angular Increments (Events)	6-12
List of Switch States	6-12
Switch Settling Time	6-13
TTL Trigger and Ready Timeouts	6-13
Using More than One Controller	6-14
Starting Run-Time Mode	6-14
Run-Time Measurement Sequence	6-14
<i>Figure 6-2. Run-Time Flow Chart with Programming Command</i>	
References	6-16
Run-Time Measurement Sequence for Multiple Controllers	6-18
Using IMM vs. TTL Trigger for Source 1	6-18
<i>Figure 6-3. Run-Time Flow Chart for Multiple Controller, Control</i>	
<i>Mode controlling REMote1</i>	6-19
<i>Figure 6-4. Run-Time Flow Chart for Multiple Controller,</i>	
<i>Remote Mode being controlled by CONToller</i>	6-20
Programming Examples	6-21
Example 1	6-21
Example 2	6-24
Example 3	6-27
HP 85330A Error Messages	6-31

7. Remote Programming Command Reference

Command Syntax	7-1
Common Command Format	7-1
Standard Command Format	7-1
<i>Table 7-1. Parameter Types</i>	7-2
Common Commands	7-3
*CLS	7-4
Syntax	7-4
Example	7-4
*IDN?	7-5
Default	7-5
Syntax	7-5
Example	7-5
*OPC?	7-6
Syntax	7-6
Example	7-6
*RST	7-7
Default	7-7

Syntax	7-7
Example	7-7
Standard Command Reference	7-8
ROUTe	7-9
Subsystem Command Syntax	7-9
ROUTe:CLOSe	7-10
Default	7-10
Syntax	7-10
Example	7-10
ROUTe:CONTRol	7-11
Default	7-11
Syntax	7-11
Example	7-11
ROUTe:DELay	7-12
Default	7-12
Syntax	7-12
Example	7-12
RUNTime	7-13
RUNTime:CONTRoller	7-14
Default	7-14
Syntax	7-14
Example	7-14
RUNTime:EVENT:COUNT	7-15
Default	7-15
Syntax	7-15
Example	7-15
RUNTime:EVENT:TRIGger	7-16
TTL Mode	7-16
IMM Mode	7-16
Default	7-16
Syntax	7-16
Example	7-16
RUNTime:INITiate:IMM	7-17
Default	7-17
Syntax	7-17
Example	7-17
RUNTime:SOURce:COUNT	7-18
Default	7-18
Syntax	7-18
Example	7-18
RUNTime:SOURce:SOURCE1:TRIGger	7-19
Default	7-19
Syntax	7-19
Example	7-19
RUNTime:SOURce:SOURCE2:TRIGger	7-20
Default	7-20
Syntax	7-20

Example	7-20
RUNTime:SWITCh:DELay	7-21
Default	7-21
Syntax	7-21
Example	7-21
RUNTime:SWITCh:SCAN	7-22
Default	7-22
Syntax	7-22
Example	7-22
RUNTime:SWITCh:TRIGger	7-23
Default	7-23
Syntax	7-23
Example	7-23
RUNTime:TIMEout:EVENT	7-24
Default	7-24
Syntax	7-24
Example	7-24
RUNTime:TIMEout:RECEiver	7-25
Default	7-25
Syntax	7-25
Example	7-25
RUNTime:TIMEout:REMote	7-26
Default	7-26
Syntax	7-26
Example	7-26
RUNTime:TIMEout:SOURce	7-27
Default	7-27
Syntax	7-27
Example	7-27
SYSTem	7-28
SYSTem:ERRor?	7-29
Default	7-29
Syntax	7-29
Example	7-29

8. In Case of Difficulty

The HP 85330A Does Not Show the Main Menu When Turned ON ..	8-11
---	------

9. Service

Introduction	9-1
Theory of Operation	9-2
<i>Figure 9-1. HP 85330A System Block Diagram</i>	9-3
<i>Figure 9-2. HP 85330A Timing Sequence of a Typical</i> <i>Measurement</i>	9-6
<i>Table 9-1. Timing Sequence Trigger Widths</i>	9-6
Recommended Test Equipment	9-8
<i>Table 9-2. Required Test Equipment</i>	9-8
Service	9-9

Troubleshooting	9-10
Troubleshooting the System	9-10
Troubleshooting the Multiple Channel Controller	9-10
<i>Table 9-3. SWITCH PORT 1/2 Connector Pinout</i>	9-11
Troubleshooting the Switch Control Unit	9-11
Troubleshooting the RF Switch	9-11
Troubleshooting the Cables	9-11
<i>Table 9-4. HP 85383A Connector Wiring Table</i>	9-12
<i>Table 9-5. HP 85385A Wiring</i>	9-13
Replaceable Parts	9-14
Parts List Description	9-14
Ordering Information	9-14
Replaceable Parts	9-14
<i>Figure 9-3. HP 85330A System Identification Diagram</i>	9-15
Mainframe, Plug-in Cards	9-16
<i>Table 9-6. HP 85330A Mainframe Replacement Parts</i>	9-16
Switch Control Unit	9-17
<i>Table 9-7. HP 85331/2 Switch Control Unit Replacement Parts</i>	9-17
RF Switch	9-17
<i>Table 9-8. HP 85331/2 Switch Replacement Parts</i>	9-17
Interconnect Cables	9-18
<i>Table 9-9. HP Replacement Interconnect Cables for HP 85330/31/32</i>	9-18
Assembly and Disassembly	9-19
Mainframe	9-19
E1330 Card Configuration	9-20
85330-60002 Card Configuration	9-20
Switch Control Unit	9-21
Adjustments	9-23
Selecting Positive or Negative-Edge Event Triggers	9-23
<i>Figure 9-4. Positive/Negative-Edge EVENT TRIG jumpers</i>	9-24
Selecting the Multiple Channel Controller's HP-IB Address	9-24
Switching From the Internal to External Power Supply	9-25
<i>Table 9-10. AUX Power in Pinouts</i>	9-25
Required Mating Connector	9-25
Preventive Maintenance	9-26

10. Accessory Documentation

11. Glossary

1

Installation

Installation at a Glance

The installation procedure is composed of the following basic steps:

1. If you just purchased an antenna measurement system, install all components as described in the documentation that came with that system. Do not connect the HP 85330A yet.
2. Turn on the system and perform a functional check.
3. If desired, verify the performance of the system components by referring to the Performance Verification chapter of the system manual.
4. Install and verify the HP 85330A system as explained in this manual.

Preparing the Main Antenna Measurement System

CAUTION

As an antistatic precaution *do not touch exposed connector contacts!*

Information about installing, performing an operational check, and verifying the main antenna measurement system is explained in the appropriate documentation listed below:

- *HP 85301B Antenna Measurement System Manual*
- *HP 85301C Antenna Measurement System Manual*
- *HP 85310A Distributed Frequency Converter Manual*

If you purchased an HP 8511 as a stand-alone unit, refer to the *HP 8530A On-Site Service Manual* for installation instructions. Verify the HP 8511 as explained in its operating and service manual.

Installing the HP 85330A Multiple Channel Controller

Choosing the Proper Configuration

There are two ways to install the HP 85330A system. Figure 1-1 on page 1-3 is a flow chart that shows a installation configuration that is appropriate for you to use.

How to use the figure

Follow the flow chart from the top. Determine if your measurements are made with a single frequency (CW), or multiple frequencies. Proceed down the appropriate flow chart path. Proceed in this way until you get to a box that recommends either Figure 1-2 on page 1-4, or Figure 1-3 on page 1-5.

Fast Source Control

Fast source control *speeds up frequency switching speed* in multiple-frequency measurements. It is only available in systems that use two HP 836xx series synthesized sources. This mode uses TTL signals to increment RF and LO source frequency, providing faster frequency switching speeds than are possible under HP 8530A control. In the fast source control configuration, the system's computer must set up the sources with appropriate frequency settings, triggering mode, and so on. When automatic **Run Time** measurement mode is engaged, the HP 85330A automatically increments the RF and LO source frequencies using TTL

lines. More information is provided in Chapter 6, “Programming”. When the sources are controlled by a computer, the SCPI language mode must be selected. This is shown in Figure 1-3 on page 1-5.

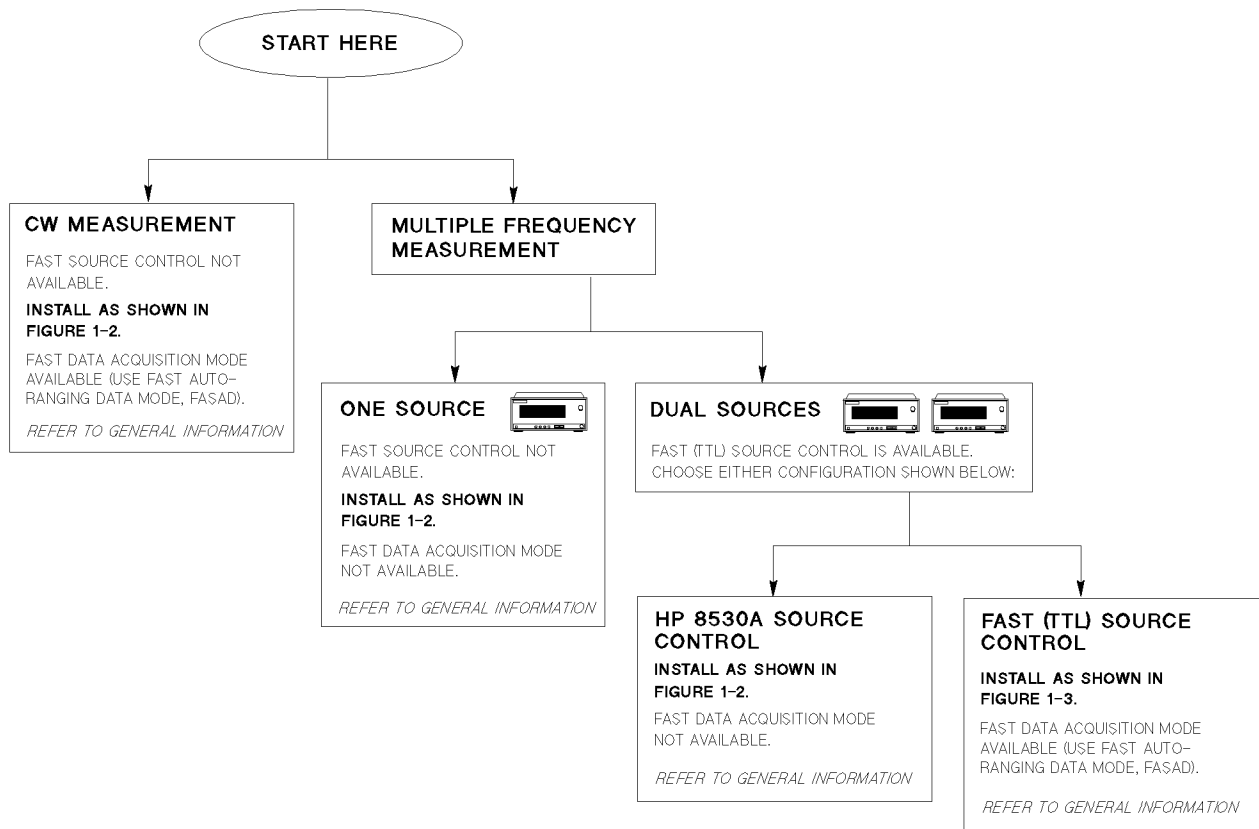

FLOWINST.GAL

Figure 1-1 *Flow Chart for Choosing the Correct Installation*

NOTE

If the receiver does not have the RECEIVER READY, as shown in Figure 1-2 on page 1-4 and Figure 1-3 on page 1-5, then the STOP SWEEP may be used.

Installation
 Preparing the Main Antenna Measurement System

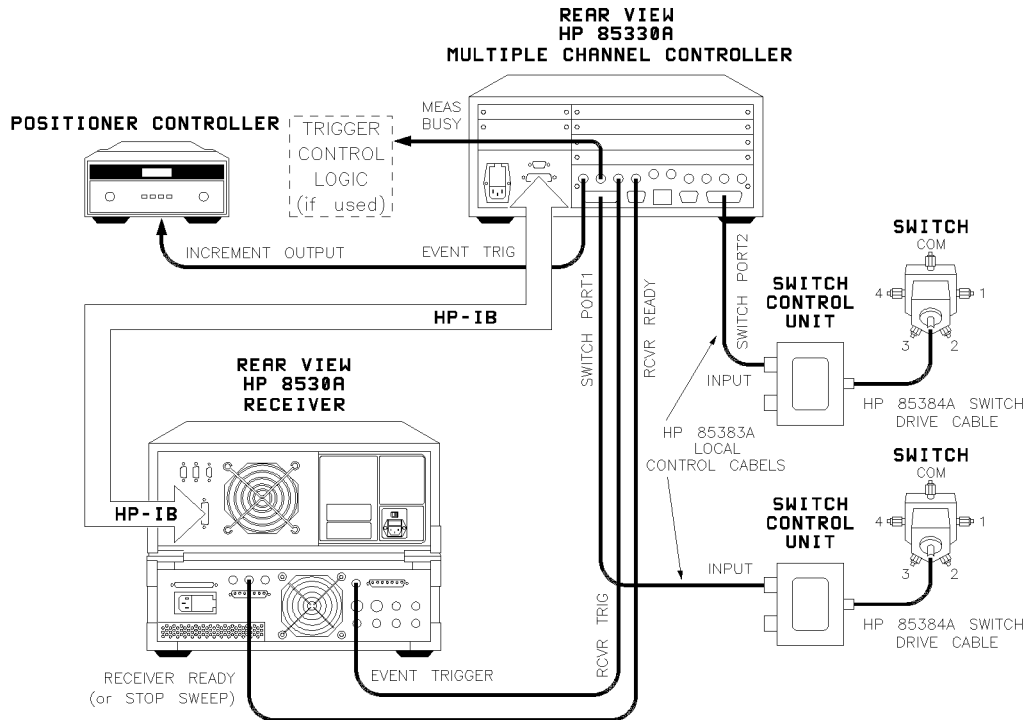

Figure 1-2 HP 85330A Installation Diagram for HP 8530A Source Control

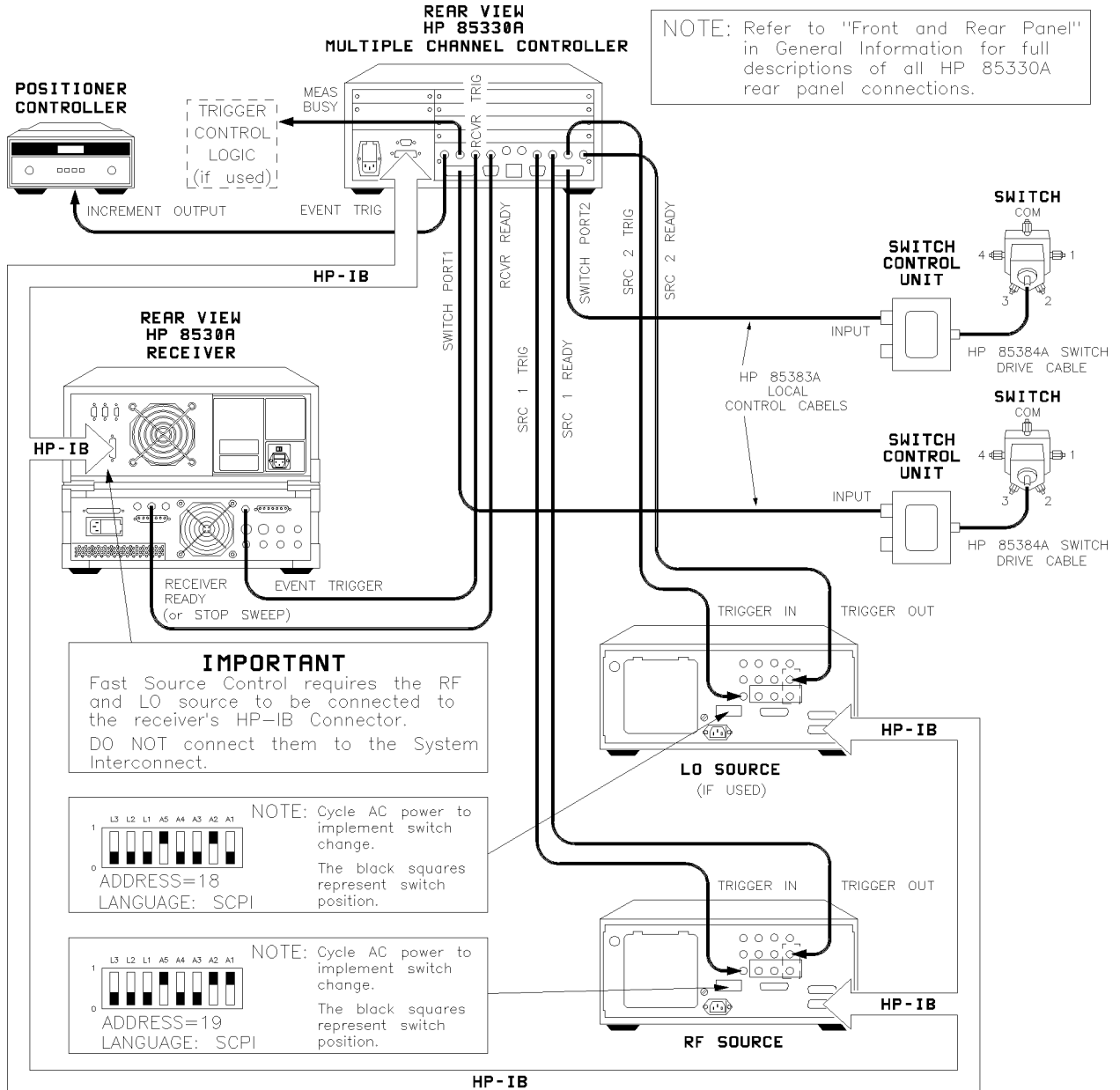

Figure 1-3 HP 85330A Installation Diagram for Fast (TTL) Source Control

Checking Operation of the Multiple Channel Controller

Turn the Multiple Channel Controller ON, the following screen should appear:

```
Select an instrument._  
SYSTEM 85330A IBASIC (see note below)
```

NOTE

IBASIC is only present if the IBASIC option is installed.

If the display shows "DIG I/O" instead of "85330A" then the drivers are no longer loaded.

If you do not see this display, load the VXI mainframe downloadable driver files as explained in "Loading the Driver from a Personal Computer"

The HP 85330A contains HP 85330A driver files from the disk labeled HP 85330A Downloadable Driver Disk. When your system was shipped, the driver files were already loaded into the non-volatile memory of the HP 85330A mainframe. Once loaded, it will remain when the mainframe is powered down or when the power is interrupted to the mainframe.

If you *must* reload the drivers, a complete set of instructions are included in the *INSTALL.TXT* file on the supplied driver disk, or perform the following instructions:

NOTE

This method uses a personal computer (PC) to download the drivers over a serial cable (supplied).

NOTE

The downloadable driver disk *should not* be set to the write-protected position or the driver files will not load properly.

Loading the Driver from a Personal Computer

Equipment Needed

The following equipment was supplied with your system:

- Serial Cable: HP 24542U, 9-pin to 9-pin
- Adapter: 5181-6641, 9-pin to 25-pin (only needed if your computer has a 25-pin serial connector)
- Downloadable Driver Disk: p/n 85330-10016 (rev A.02.31 or higher)

NOTE

You can use other com ports, such as com2. However, you have to edit a file called "VXIDLD.CFG" so the software knows you are using a different port. This configuration file can be edited with any ASCII text editor, such as notepad. Save the changed file back to the supplied disk.

NOTE

HP recommends that you make two backups of the driver disk. Make one copy to a floppy disk, and one copy to the personal computer used with the system.

Procedure

1. Disconnect any HP-IB cables from the mainframe. If it is easier, you can disconnect the HP-IB from the back of the system controller computer.
2. Turn the VXI mainframe ON.
3. On your PC, open a DOS command prompt window.
4. Insert the supplied driver disk into drive A (do not write-protect the downloadable driver disk. The driver will not load if the write-protect window is open. Make sure the tab is snapped fully into the closed portion.)
5. In the DOS command prompt window, change to drive A.
6. In the DOS command prompt window type `VXIDLD` and press [Enter].
7. The mainframe download procedure takes approximately six or seven minutes, and the mainframe will reboot.

NOTE

There are several error messages that can be ignored. These are described in the README.TXT File on the driver disk. Specifically, refer to the description of the VXIDLD.CFG file.

8. Reconnect all the HP-IB cables.
9. When finished, the following should be displayed:

Select and instrument._

SYSTEM 85330A IBASIC (see note below)

NOTE

IBASIC is only present if the IBASIC option is installed.

Viewing or Changing the Multiple Channel Controller's HP-IB Address

The factory default setting of the HP-IB address is 9. To view the HP-IB address:

Press [Select Instr] {SYSTEM} {HP-IB} {READ}

To change the current HP-IB address:

1. Press [Select Instr] {SYSTEM} {HP-IB} {SET}
2. Enter the new address and press [Return]

Selecting Positive or Negative-Edge Event Triggers

By default, the positive-edge of the EVENT TRIG line starts the measurement. To change this so a negative-edge starts the measurement, perform the following procedure.

CAUTION

This device contains devices that are sensitive to static discharge. When you remove the cover of this device, observe static safety precautions:

1. Place the unit on a grounded anti-static mat.
2. Wear a grounded wrist strap. Foot straps are only acceptable if you wear one on each foot, and if you are standing on a grounded floor mat.

Refer to Figure 1-4 on page 1-10.

Installation
Selecting Positive or Negative-Edge Event Triggers

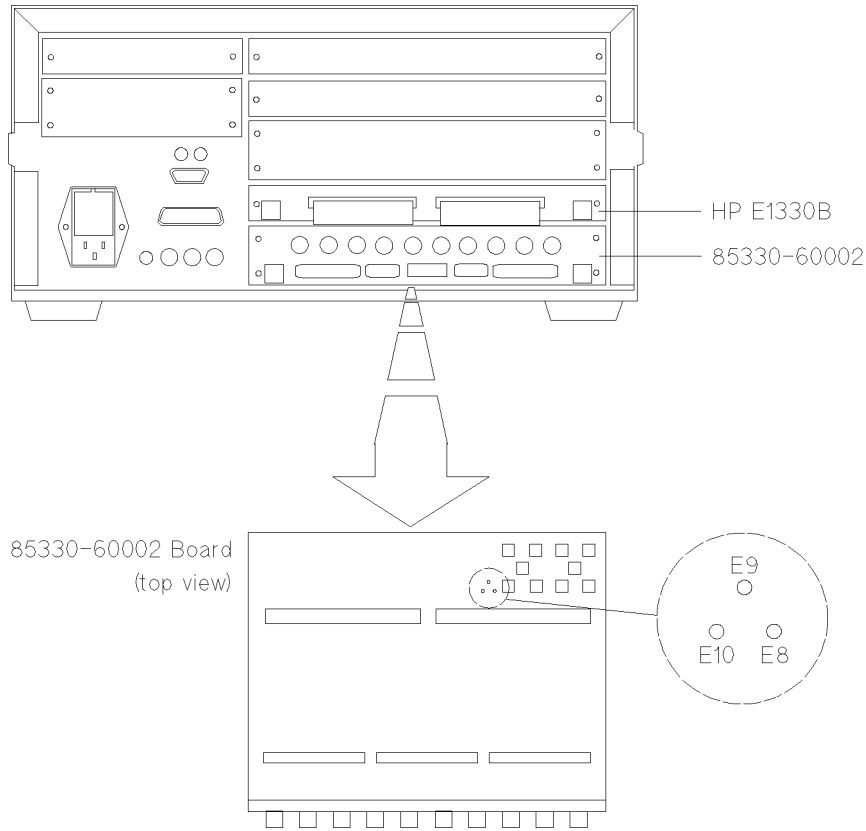

Figure 1-4 Positive/Negative-Edge EVENT TRIG jumpers

1. Remove the two screws that hold the HP E1330B board in place.
2. Remove the four screws that hold the 85330-60002 board in place.
3. Pull out the two boards at the same time. You can do this by pulling each one out a little at a time, until they are both removed. *Place the boards on an anti-static surface.*

Standard positive-edge operation is set at the factory by jumpering E9 and E10 together.

4. To select negative-edge operation, move the jumper across E9 and E8.
5. Reinstall the boards and screws.

Installing the Switch Control Units and Switches

Mounting the SCU and RF Switch

If desired, you can mount the SCU using the supplied mounting screws. You must provide a mounting plate or drill holes in an existing structure before mounting an SCU or a switch. Refer to the mounting diagram in Figure 1-5 on page 1-12.

NOTE

Make sure the HP 85383A local control cable can reach from the Multiple Channel Controller to the SCU. Make sure the HP 85384A switch drive cable is long enough to reach from the SCU to the switch.

Switch Control Unit Configuration Switches

Changing any of the DIP switches inside the SCU is *not* recommended. All switch settings are made at the factory.

In a *standard system* (defined below), the following settings are used:

- SCU address is set to 0.
- Channel numbers 1 through 4 are used to select switch positions.

A “standard system” uses one HP 85330A with one or two switch control units, each with a two-throw or four-throw switch module. Remember that HP 85330A PORT 1 and PORT 2 are addressed independently. So:

- If you have two SCUs, both can use the default SCU address (0).
- You can use the default channel number assignments (1 through 4) for *both* switch modules. Since each SCU is on a different port, and each port is addressed independently, there is not a channel number conflict.

Installation
Installing the Switch Control Units and Switches

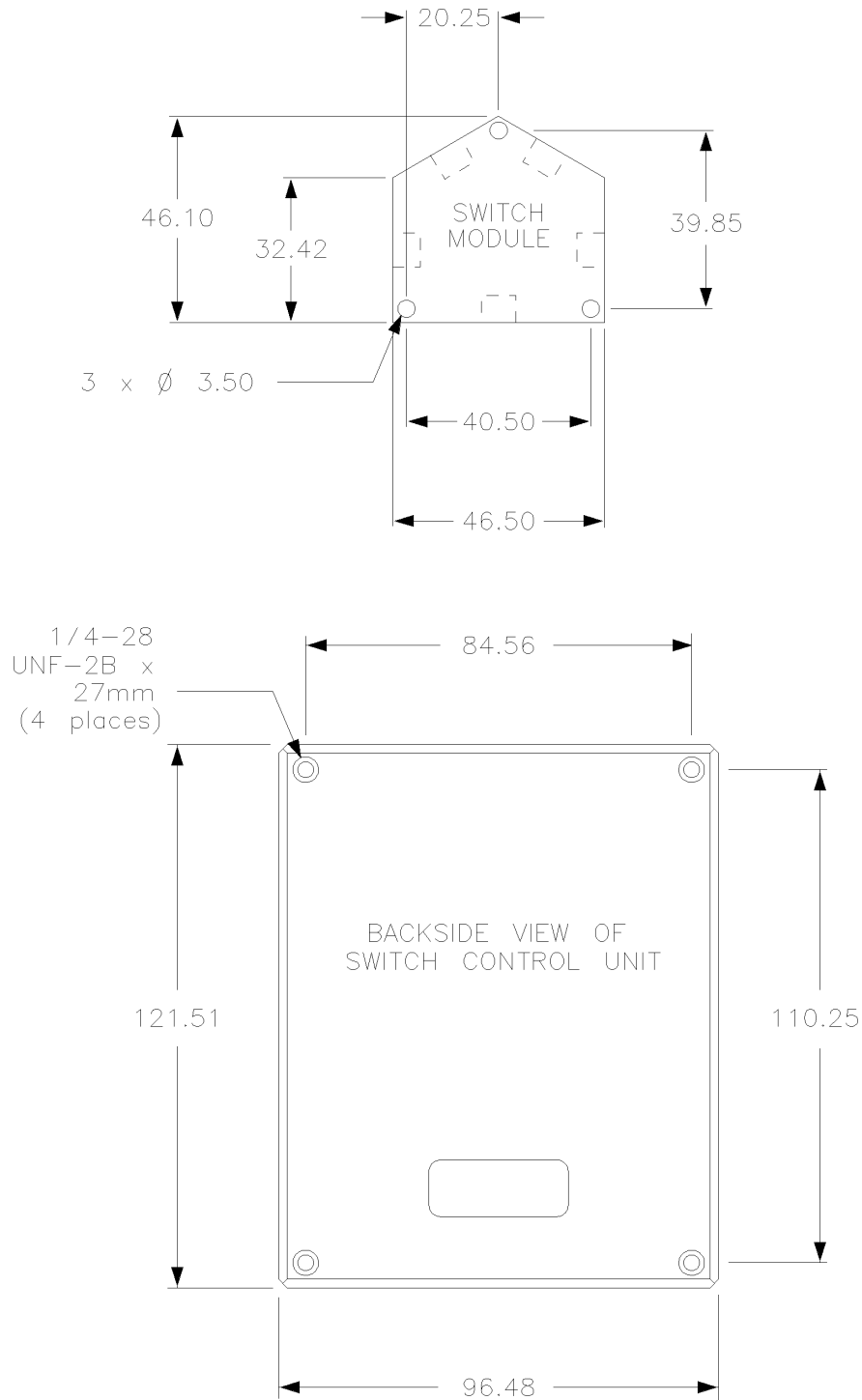

NOTE: All dimensions are in millimeters (mm)

Figure 1-5 SCU and Switch Mounting Diagram

2

Performance Verification

In this Chapter

- Recommended performance verification test equipment
- Performance verification tests
- Verifying the Multiple Channel Controller
- Verifying the RF switches

Description

This performance verification should be done once a year, or more frequently as needed. This procedure verifies that the HP 85330A System meets or exceeds its published specifications. Specifications are listed in Chapter 4, “General Information”. If traceability to a local standards organization is required, then it can be done with this procedure. One such standards organization is the United States National Institute of Standards and Technology (NIST, formerly NBS).

This verification can be performed at the measurement system’s site, or at a service bench. The verification will verify all parts of the multiple channel system; multiple channel controller, switches, and cables. This verification does not check the performance of the measurement systems’s transmitter or receiver. Use the measurement system’s manual for more information on that procedure.

Recommended Equipment

Table 2-1 lists the equipment that is mandatory when performing the performance verification.

Table 2-1 Required Equipment

Qty	Item	HP Part or Model Number ¹
1	Downloadable Driver Disk, rev A.03.00	85330-10016 ²
1	Multimeter (20 Vdc, digital)	E2377A
1	Digital Oscilloscope (100 MHz bandwidth 1 MHz Single-shot bandwidth)	HP 54501A
1	Tee adapter (BNC male to female, female)	1250- 0781
3	Cable (BNC male to male 122 cm)	8120-1840
1	Network Analyzer System ³ (50 MHz to 40 GHz ^{4, 5} 90 dB dynamic range)	HP 8722C (option 003)
1	Plotter or Printer ⁶	HP 7550A+, or LaserJet
1	Torque wrench (2.4/3.5 mm @ 8 in-lb)	8710-1765 ⁷

1. Other part numbers or model numbers may be used if they meet the minimum requirements.

2. Included with HP 85330A shipment.

3. System must include vector network analyzer, test port cables and a calibration kit.

4. A 50 MHz to 26.5 GHz network analyzer may be used if the 3.5 mm adapters are used with the microwave switches.

5. If a network analyzer is used with a frequency range less than the switches, the performance verification will only be valid over the frequency range of the network analyzer.

6. Plotter or printer must be connected to the network analyzer and oscilloscope for test documentation.

7. Use this wrench for any 2.4/3.5 /SMA mm connections in this procedure.

Performance Verification Test

The following verification procedure will verify the HP 85330 system in two parts. The first part will verify the operation of the Multiple Channel Controller to make sure that it is controlling the switches and the receiver correctly. The second part will check the switch's RF performance and to make sure that they are switching correctly.

Setting Up the Equipment

HP 85330 System

Connect the HP 85330 system to the Switch Control Unit using the correct local control cable. This should be set up the same way that the HP 85330A system is used in the measurement system (HP 85301B/C). *Do not* connect the Switch Control Units (SCU) to their Switches at this time. *Do not* connect the HP 85330A to any other instruments in the measurement system. An example of a set up is shown in Figure 2-1. Do not turn ON the HP 85330A at this time.

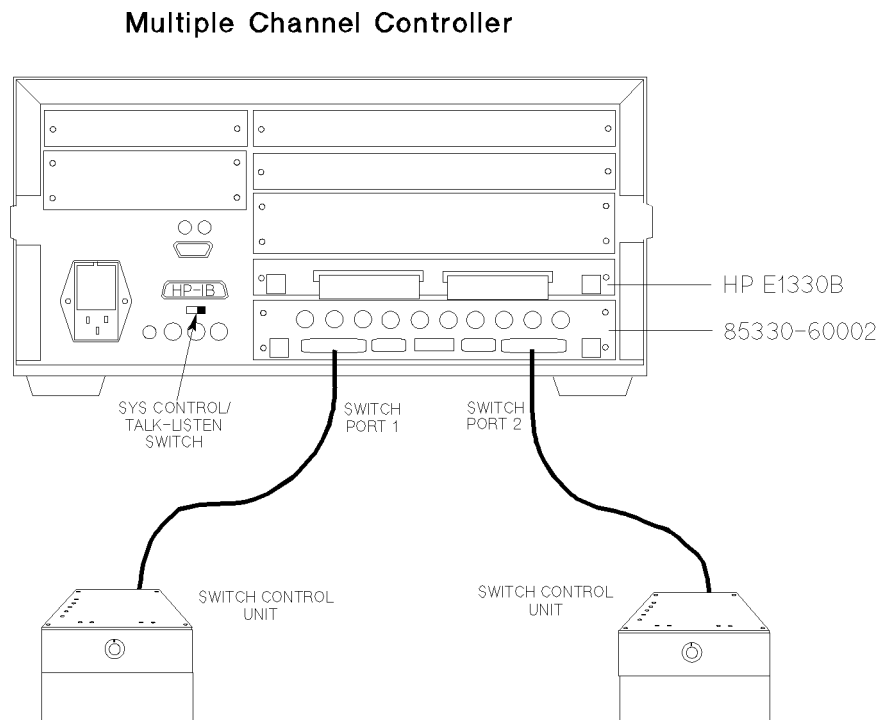

Figure 2-1 An Example Performance Verification Setup

Digital Oscilloscope

Set up the HP 54503A digital oscilloscope (or any oscilloscope) as described in the following procedure, using the same settings.

NOTE

The oscilloscope set up described in the following procedure *will not* display a trace on the oscilloscope screen until a pulse is initiated. The oscilloscope will then hold the trace until the [CLEAR DISPLAY] is pressed.

Procedure

Turn ON the oscilloscope and press the following keys on the HP 54503A:

[CHAN]: {1}

{ON}

{2v/Div}

{Offset: 0v}

{Coupling: DC}

{Input: 1 M Ω }

{Probe Ratio: 1:1}

[CHAN]: {2}

{ON}}

{2v/Div}

{Offset: 5v}

{Coupling: DC}

{Input: 1 M Ω }

{Probe Ratio: 1:1}

[TRIG]:

{Trig'd}

{Edge}

{Source: 1}

{Adjust: 1v}

{ \square } (- Edge)

[TIMEBASE]:

{2 us/Div}

{Delay: 0}

{Reference: Cntr}

[SAVE] [1]

Network Analyzer

Turn ON the vector network analyzer. Adjust the controls for the following setup:

Measurement Display

Display:	4 Channel	
Channel 1:	S11	SWR
Channel 2:	S21	Log Mag
Channel 3:	S12	Log Mag
Channel 4:	S22	SWR
Domain:	Frequency	
Start Frequency:	45 MHz	
Stop Frequency:	40 GHz	
Number of Points:	201	
RF Source Power:	Maximum	
Measurement:	Continuous	
Averaging:	As required	

Setup the rest of the measurement display for your convenience and ease of viewing.

Cables

Connect one test port cable to Port 2 of the test set. The RF switch will be connected directly to the test set Port 1. An example of this setup is shown in Figure 2-5 on page 2-13.

Calibration

Perform a full, two port calibration at the test set Port 1, and at the end of the test port cable connected to Port 2.

Save Setup

Save this instrument state setup in Save/Recall register 1. It will be used later in the tests. Press:

[SAVE] {1}

Verifying the Multiple Channel Controller

This portion of the verification will check the HP 85330 multiple channel switch controller to ensure that it is operating correctly. It will also check the Switch Control Unit of the HP 85331/2 to make sure that it is switching correctly. Document the test results by plotting or printing the test instrument screens as each test is performed.

Turn-On

Turn the Multiple Channel Controller ON, the following screen should appear:

```
Select an instrument._  
  
SYSTEM  85330A  IBASIC (see note below)
```

NOTE

IBASIC is only present if the IBASIC option is installed.

If you see the above display, the unit has passed its turn on tests and is working properly. If you *do not* see this display, load the HP85330A downloadable driver files as explained in the “Loading the Driver from a Personal Computer” on page 1-6.

Voltage Check

Check the voltage on the switch control unit’s OUTPUT connector. This is the connector that is used to daisy-chain the switch control units together. The voltages are shown in Table 2-2. If an external power supply is used to bias the switch control units, the supply may require some adjustment to keep the voltage within the tolerances.

Table 2-2 *Switch Control Unit Voltages*

Pin	Voltage
E, L, V	+12 \pm 1.8 Vdc
a	-12 \pm 1.8 Vdc
F, M, W, b	ground

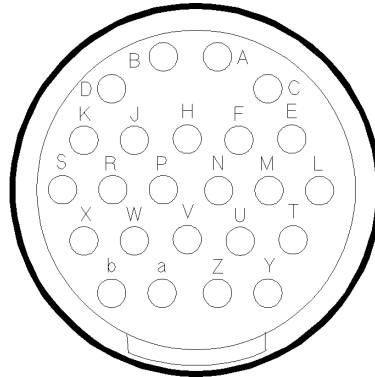

Figure 2-2 *Switch Control Unit Output Connector Voltages*

Inputs/Outputs

Press the following on the Multiple Channel Controller:

[Clear Instr] [Select Instr]

You should see the following display:

```
Select an instrument._
```

```
SYSTEM  85330A  IBASIC (see note below)
```

NOTE

IBASIC is only present if the IBASIC option is installed.

This in the MAIN MENU.

Output Trigger Test

The following test will determine if the rear panel ports output the correct signals. Note that a single press on the specific *{TRIGGER}* key will cause a single trigger pulse. If you hold down this key, a train of trigger pulses will be outputted.

1. Connect a BNC cable between Channel 1 of the oscilloscope and the Multiple Channel Controller rear panel BNC connector that is being tested.
2. On the oscilloscope press:
[RECALL] [1]
3. Connect the BNC cable to the RCVR TRIG connector on the Multiple Channel Controller, and press:

```
{85330A} {TRIGGER} {RCVR}
```

On the oscilloscope press [CLEAR DISPLAY]. You should see a negative pulse, with an approximate width of one to three microseconds.

4. Connect the BNC cable to the SRC 1 TRIG connector on the Multiple Channel Controller, and press:

{SRC_1}

On the oscilloscope press [CLEAR DISPLAY]. Set the [TIMEBASE] to *{5 us/Div}*. You should see a positive pulse, with an approximate width of 10 to 14 microseconds.

5. Connect the BNC cable to the SRC 2 TRIG connector on the Multiple Channel Controller, and press:

{SRC_2}

On the oscilloscope press [CLEAR DISPLAY]. You should see a positive pulse, with an approximate width of 10 to 14 microseconds.

6. Remove the BNC cable from the Multiple Channel Controller.

Pulse Receive and Cycle Test

The following test will determine if the rear panel ports successfully sense the trigger pulses. These tests will output a train of 100 pulses.

1. Press the following on the Multiple Channel Controller:

[Clear Instr] [Select Instr] *{85330A}*

2. Connect a BNC cable between the RCVR READY and RCVR TRIG connectors. Press:

[More] *{TEST}* *{RCVR}* [1] [0] [0] [Return]

If the test is successful the RCVR menu will appear on the display. If the test fails, the following error message will appear:

-214, Trigger deadlock

3. Connect a BNC cable between the SRC1 READY and SRC1 TRIG connectors. Press:

{SRC_1} [1] [0] [0] [Return]

If the test is successful the RCVR menu will appear on the display. If the test fails, the following error message will appear:

-214, Trigger deadlock

4. Connect a BNC cable between the SRC2 READY and SRC2 TRIG connectors. Press:

{SRC_2} [1] [0] [0] [Return]

If the test is successful the RCVR menu will appear on the display. If the test fails, the following error message will appear:

-214, Trigger deadlock

5. Remove the BNC cable from the Multiple Channel Controller.

Counter Pulse Delay Test

The following test determines if the on-board counter is operating correctly.

1. Connect BNC cables between the SRC1 TRIG, RCVR READY connectors and the oscilloscope as shown in Figure 2-3 on page 2-10.
2. On the oscilloscope press:
[RECALL] [1]
[TRIG] {Source 2} {Adjust: 1.5v} { \square } (+ Edge)
[TIMEBASE] {1 us/Div} {Delay: 4 us} {Ref: Centr}
[SAVE] [2]
3. Press the following on the Multiple Channel Controller:
[Clear Instr] [Select Instr] {85330A} {RESET} [More] {TEST} {COUNTER}
4. Press the following on the Multiple Channel Controller:
[4] [Return]
5. The negative edge of the displayed pulse should be 4 ± 1 microseconds.
To use the scope measurement feature, press: [$\Delta t \Delta v$] { Δt Marker: ON}.
Rotate the front panel knob until the vertical marker line intersects the negative edge of the pulse. Note that the Start Marker reading will be the pulse delay. See Figure 2-4 on page 2-10 for more information.
6. On the oscilloscope press:
[TIME BASE] {1 us/Div} {Delay: 1000 us} [CLEAR DISPLAY]
7. Press the following on the Multiple Channel Controller:
[1] [0] [0] [0] [Return]
8. The negative edge of the displayed pulse should be $1,000 \pm 1$ microseconds.
To use the scope measurement feature, press: [$\Delta t \Delta v$] { Δt Marker: ON}.
Rotate the front panel knob until the vertical marker line intersects the negative edge of the pulse. Note that the Start Marker reading will be the pulse delay. See Figure 2-4 on page 2-10 for more information.
9. On the oscilloscope press:
[TIME BASE] {2 us/Div} {Delay: 15 ms} [CLEAR DISPLAY]
10. Press the following on the Multiple Channel Controller:
[1] [5] [0] [0] [0] [Return]
11. The negative edge of the displayed pulse should be 15 ± 0.001 milliseconds.
To use the scope measurement feature, press: [$\Delta t \Delta v$] { Δt Marker: ON}.
Rotate the front panel knob until the vertical marker line intersects the

Performance Verification
Verifying the Multiple Channel Controller

negative edge of the pulse. Note that the Start Marker reading will be the pulse delay. See Figure 2-4 for more information.

12. Remove the BNC cables.

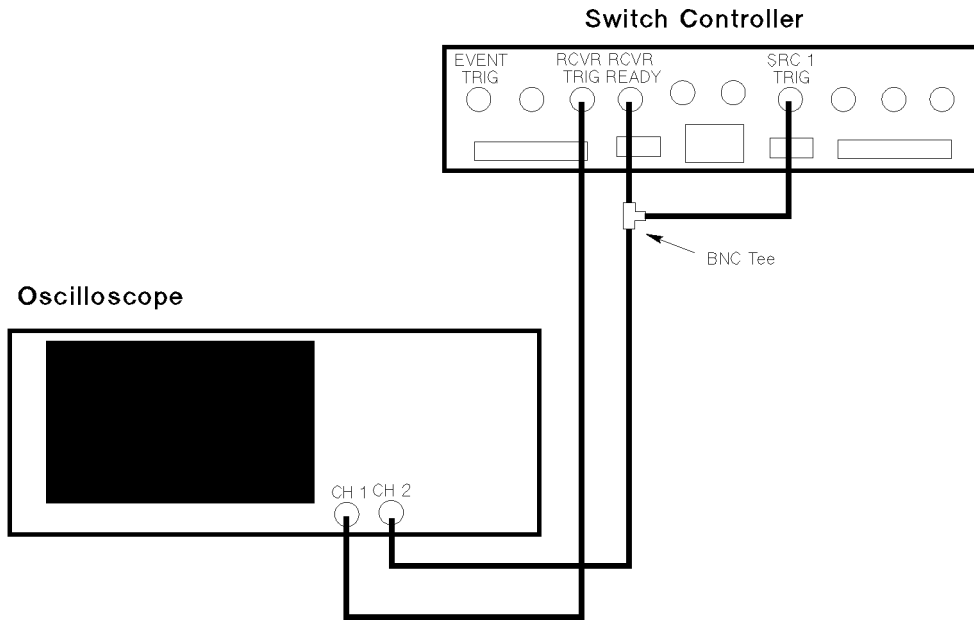

Figure 2-3 Counter Pulse Delay Test Setup

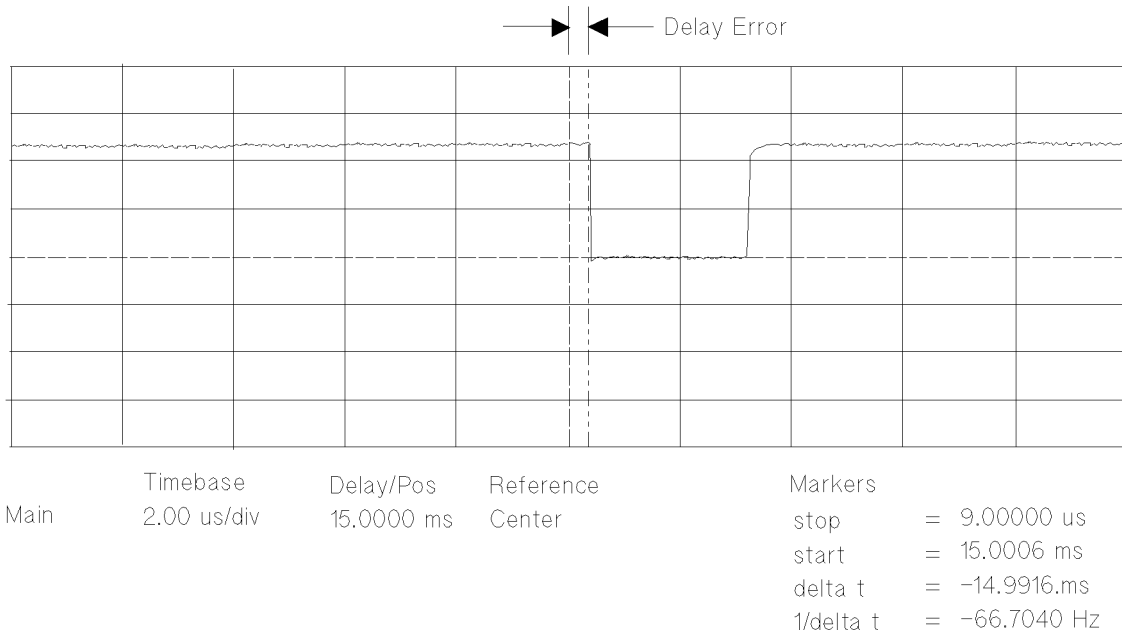

Figure 2-4 15 millisecond Delay Trigger Example

Measurement Busy Signal and Pulse Width Test

The following test will determine if the MEAS BUSY port output pulse width is correct. It will also test the EVENT TRIG input.

1. Connect a BNC cable between the SRC1 TRIG and EVENT TRIG connectors.
2. Connect a BNC cable between the MEAS BUSY connector and the oscilloscope channel 1.
3. On the oscilloscope press:
[TIME BASE] {10 us/Div} [CLEAR DISPLAY]
4. Press the following on the Multiple Channel Controller:
[Clear Instr] [Select Instr] {85330A} [More] {TEST} {EVENT} [1] [Return]
5. While the measurement is cycling, observe the MEAS BUSY pulse on the oscilloscope. The pulse width should be approximately 50 microseconds.
6. If the test is successful the RCVR menu will appear on the display. If the test fails, the following error message will appear:

-214, Trigger deadlock

Verifying the Switch Control Unit

This test will determine if the Multiple Channel Controller is controlling the Switch Control Unit and that the SCU is operating correctly. If the system has more than one SCU on a single port, then check *each* SCU.

1. Check to make sure that the Multiple Channel Controller is connected to each switch control unit. An example of this setup is shown in Figure 2-5 on page 2-13.
2. Check each switch control unit. The Active light should be ON.
3. Press the following on the Multiple Channel Controller:
`[Clear Instr] [Select Instr] {85330A} {CLOSE}`
4. Select *{PORT 1}* or *{PORT 2}* depending on the setup of your switch system. If your system uses both PORT 1 and PORT 2, then perform the following tests for both ports:
 - a. Press:
{PORT 1} or *{PORT 2}*
 - b. Enter each switch control unit's address and switch number and observe that unit's lights. As each switch address is activated, the light should turn ON.

To enter a unit address and switch number, then press:

`[x] [y] [z] [Return]`

x = switch control unit's address. (normally 0)

y = switch number to be closed. (normally 0)

z = switch number to be closed. (0 = opens all switches.)

For example, *{PORT 1}* [1] [0] [3] [Return] will close switch 3 in the switch control unit with address 1 that is connected to PORT 1. The switch control unit address can be found on the units label. To close switch 4, just press [1] [0] [4].

- c. Close each switch on a module and insure that the light turns ON.
5. Perform the above test for each Switch Control Unit in the system.

Verifying the RF Switches

This portion of the verification will check the Switches to make sure that they are switching correctly. This portion will also test the RF performance of the switches.

Switch Setup

1. Turn OFF the Multiple Channel Controller before making any connections.
2. Connect each switch to its switch control unit. Use the supplied switch drive cable.
3. Connect the switch to the network analyzer. An example of this setup is shown in Figure 2-5. Note that all of the switch ports will be tested, so make sure that there is enough room to connect all of the ports to the network analyzer.
4. Turn ON the Multiple Channel Controller.

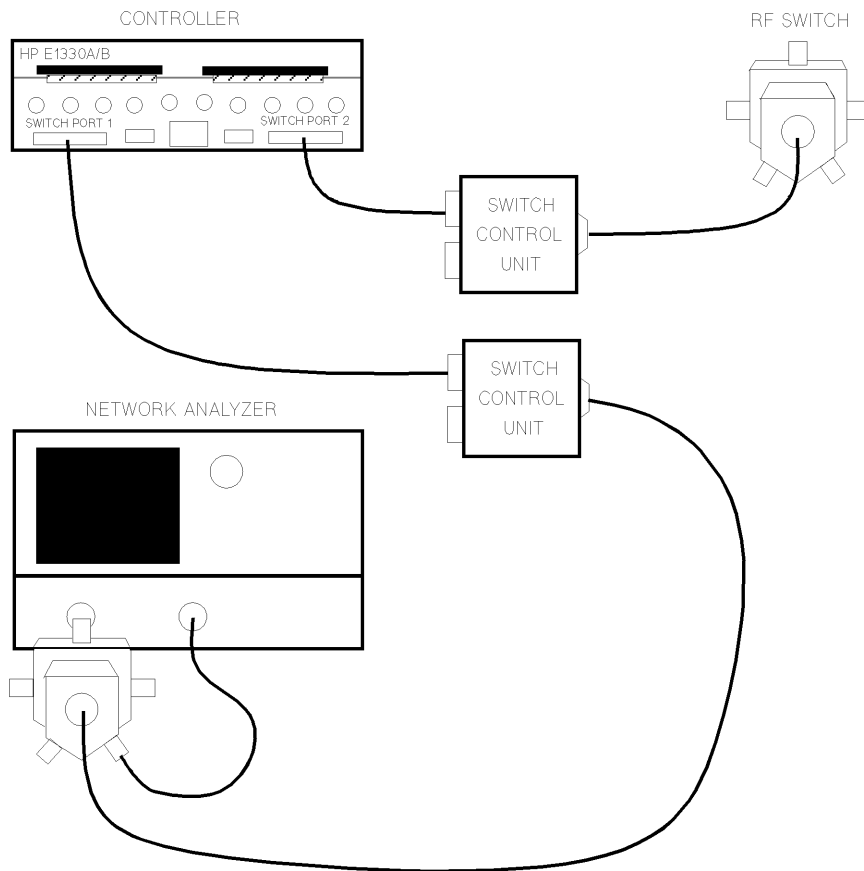

Figure 2-5 RF Switch Test Setup

RF Performance Tests

Recall the network analyzer setup that was save earlier by pressing:

[RECALL] {1}

Perform each of the following tests on each input and output port of the switch. Check the results of each of the tests against the switch's specifications shown in the *HP 85331A/HP 85332A User's Manual*.

1. Connect the test port cable to the first switch port.
2. Close the switch path. This will turn the switch light ON on the switch control unit.
 - a. Check the S11, (input match, ON).
 - b. Check the S22, (output match, ON).
 - c. Check the S21, (insertion loss, ON).
 - d. Check the S12, (reverse insertion loss, ON).
 - e. Document the test results by plotting the display to a plotter or printer.
3. Open the switch path. This will turn the switch light OFF on the switch control unit.
 - a. Check the S11, (input match, OFF).
 - b. Check the S22, (output match, OFF).
 - c. Check the S21, (isolation, OFF). Use averaging if required.
 - d. Check the S12, (reverse isolation, OFF). Use averaging if required.
 - e. Document the test results by plotting the display to a plotter or printer.
4. Move the test port cable to the next switch port. Repeat all of the above until all switch ports are tested.

Verifying Remote Ports 1 and 2

Equipment Required

- Jumper (see below)
- Soldering iron
- 2 jumper wires

Jumpers

Figure 2-6 shows the jumper assembly that can be used to verify remote port 1 and remote port 2. Using HP part number 1251-8863 solder one wire from pin 6 to pin 8, and another wire from pin 7 to pin 9 (see Figure 2-6). A connector hood is recommended for the 9-pin connector, such as L-com (Part # SDC9AG) (<http://www.L-com.com>).

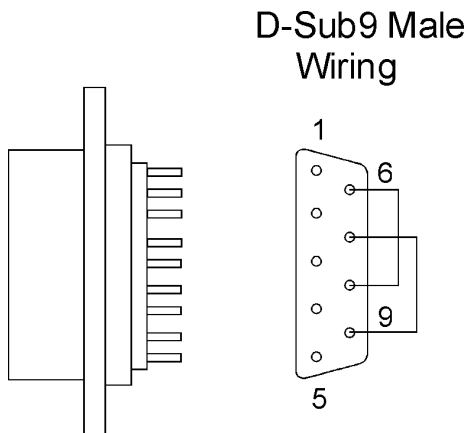

textfix3.cdr

Figure 2-6 Jumper Assembly

Remote Port 1 and remote Port 2 Test Procedure

1. Download the HP 85330A drivers Version A.03.00 or above.
2. When select instrument is displayed, press:
{85330A}, {More}, {TEST}, {More}
3. Connect the modified connector to **REMOTE 1** on the rear panel and press:
{REM_1_2}
4. The display should read:
"85330A_144:REM1 0101 PASS, REM2 1100 FAIL"
5. Move the modified connector to **REMOTE 2** on the rear panel and press:
{REM_1_2}
6. The display should read:
"85330A_144: REM1 1111 FAIL, REM2 0011 PASS"

AUX 1 and AUX 2

Pulse Test

You can output one or more 500 μ s pulses from AUX 1 or AUX 2 and measure them with an oscilloscope. The number of pulses is selectable. The pulses have a 50% duty cycle, and thus a total period of 1 ms. The amplitude of the signal is roughly 0 to 4 volts. The pulses are not perfect square waves. The leading edge rises higher than 4 volts, then curves down to approximately 4 volts.

Measuring Pulses from AUX 1 or AUX 2

1. Connect an oscilloscope to the AUX 1 or AUX.
2. Set the scope as necessary to view the waveform described above.
3. Press:

`[Select Instr] {85330A} {→} {TEST} {→} {AUX 1} or {AUX 2}`
4. The message TEST AUXn OUTPUT: # OF TESTS will appear.
5. Use the keyboard to enter the desired number of pulses. You can enter the number in units, or in scientific notation: For example:

100, or
1E2
6. Press the [Return] Key. The pulses will appear on the scope.

NOTE

The HP 85330A will not perform any other functions during this test. If you enter a large number, such as 1E6, it will take a while to finish. You can abort the test by cycling line power.

NOTE

To test AUX 2, use the same basic procedure as shown above.

AUX 1 and AUX 2 Output Voltage Test

The following test will determine if the rear panel ports successfully output the correct DC switch drive levels.

1. On the oscilloscope press:

[RECALL] [1]
[TRIG] {AUTO}
[CLEAR DISPLAY]

2. Press the following on the Multiple Channel Controller:

[Clear Instr] [Select Instr] {85330A}

3. Connect a BNC cable between the AUX 1 connector and channel 1 of the oscilloscope.

- a. Press:

{CLOSE} {AUX1} {0} or [f1]

The oscilloscope should show a trace of about 0 Vdc.

- b. Press:

{1} or [f2]

The oscilloscope should show a trace of about 4 Vdc.

4. Connect a BNC cable between the AUX 2 connector and channel 1 of the oscilloscope.

- a. Press:

[Clear Instr] {CLOSE} {AUX2} {0} or [f1]

The oscilloscope should show a trace of about 0 Vdc.

- b. Press:

{1} or [f2]

The oscilloscope should show a trace of about 4 Vdc.

When Finished with All Tests

All of the performance verification tests are now complete. Reconnect the HP 85330A system in the original measurement system configuration. Refer to the Chapter 1, "Installation" for more information.

3

Operator's Check

Purpose

This operator's check verifies that the HP 85330A can close switches, showing that the HP 85330A, switch control units, and switches are working. You can perform this check daily, or as desired. This is *not* a performance verification procedure (refer to Chapter 2, "Performance Verification" for more information).

Procedure

This procedure asks you to close every switch in your standard system, and look for an appropriate signal with the measurement system.

1. Press: [Select Instr] *{85330A}*
2. If the *{CLOSE}* softkey does not appear, press [Prev Menu] until it does.
3. Press: *{CLOSE}*
 - a. If the switch you want to close is connected to SWITCH PORT 1, press *{PORT_1}*
 - b. If the switch you want to close is connected to SWITCH PORT 2, press *{PORT_2}*
4. Enter the **switch address** using the numeric keypad. In a standard system, simply enter the channel number (1, 2, 3, or 4), and press [Return]. If you have a custom system, refer to the Manual Operation chapter for instructions.
5. Look at the channel LEDs on the front of the switch control unit. The light for the selected channel should be ON. This shows that the SCU is responding properly.
6. Perform a measurement with your system. The measurement system should be able to measure any signal present on the selected channel.
7. Repeat these steps for each channel on each switch port.

Operator's Check

4

General Information

In This Chapter

- Product description
- Required equipment
- Supplied equipment and software
- HP 85330A multiple channel controller characteristics
- Front panel features
- Rear panel features
- AC power cords

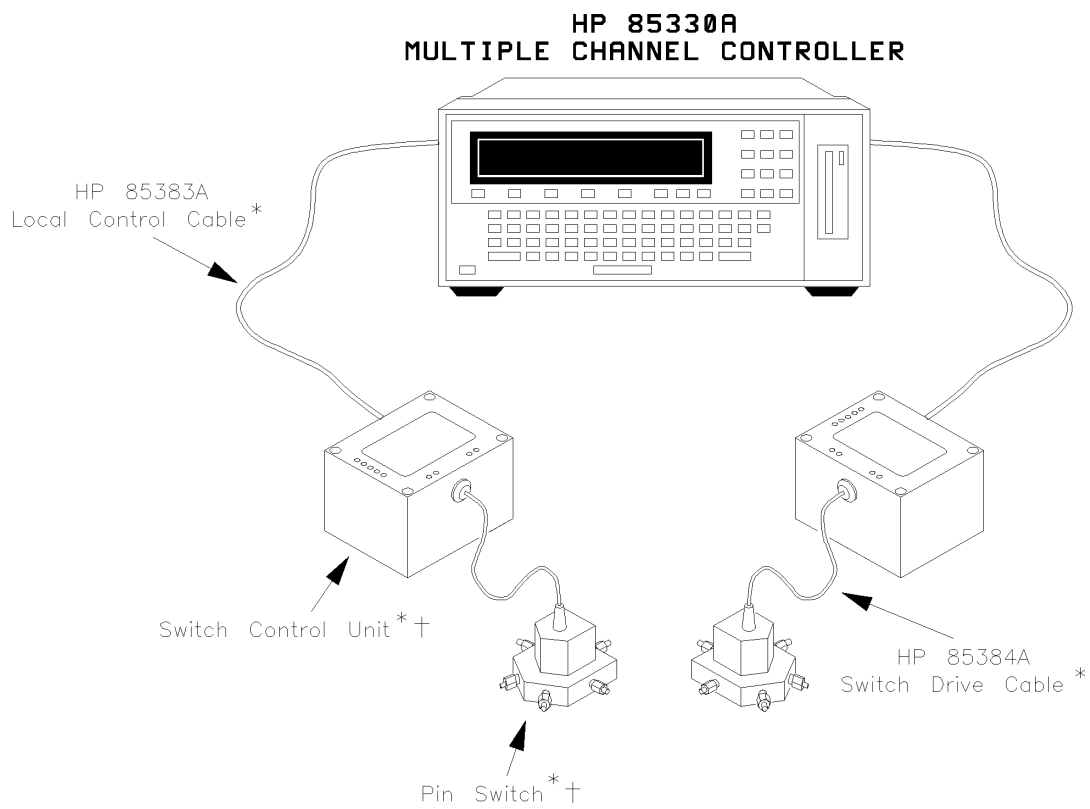

* Purchased separately from the HP 85330A.

† The Switch Control Unit and Pin Switch are sold as a single model number. The HP 85331A provides a SP2T Switch. The HP 85332A provides a SP4T Switch.

Figure 4-1 HP 85330A System Overview

Product Description

The HP 85330A multiple channel controller adds high-speed multiple-channel measurement capability to HP 8530A-based automated measurement systems, using high-isolation solid state microwave switch modules. The HP 85330A is a run time controller that orchestrates the sequencing and synchronizing of all the required functions for multiple-channel and multiple-frequency measurements; to allow very fast data acquisition speed and data throughput of the measurement system.

- **Option 908** - Rack Mount Kit Without Handles

Multiple Channel Controller rack mount kit *without handles*. To obtain this item after receiving the HP 85330A, order part number 5062-3978.

- **Option 913** - Rack Mount Kit *With* Handles

Multiple Channel Controller rack mount kit with handles. To obtain this item after receiving the HP 85330A, order part number 5062-3984.

- **Option 910** - Additional Manual

This provides an additional manual. To obtain this item after receiving the HP 85330A, order part number 85330-90019.

In-depth Information

Measurement Speed Advantages

The multiple channel controller, when used with the Autoranged Fast Data Acquisition mode, provides very fast measurement speeds. Even faster measurements can be made when the RF/LO sources are controlled using the direct TTL source control capabilities of the multiple channel controller.

Frequency states can be downloaded to the HP 8360 series of frequency synthesizers. The multiple channel controller sends TTL triggers to the sources (in two-source systems) at the appropriate time to change their frequency. This method maximizes the frequency agility of the system by allowing the sources to switch at their fastest rate.

Triggering

The HP 85330A receives triggers from the positioning system, and synchronizes the data acquisition to the positioning system. It also controls the triggering of the microwave receiver, and sequencing of the multiple channel data into the receiver.

Lowering the Workload On the Computer Controller

When using HP 85330A as the system controller, the demands of the computer are decreased during run-time. The computer is free to collect data from the receiver and perform data manipulation, display, and storage.

Installing the Detachable Power Cord

Install the instrument so that the detachable power cord is readily identifiable and is easily reached by the operator. The detachable power cord is the instrument disconnecting device. It disconnects the mains circuits from the mains supply. The front panel switch is only a *standby* switch and is not a LINE switch. Alternatively, an externally installed switch or circuit breaker (which is readily identifiable and is easily reached by the operator) may be used as a disconnective device.

Manual Operation

Front panel softkeys allow you to:

- View or change the HP 85330A's HP-IB address.
- Close any switch in the system (select a channel).
- Change the TTL state of AUX 1 or AUX 2.
- View the revision of the downloaded driver.
- Perform service functions.

Refer to Chapter 5, "Manual Operation" for more information.

Automated Operation

During automated operation, the HP 85330AHP 85330A can control switches in two ways:

Direct Control

The HP 85330A can directly control switch states and issue triggers using HP-IB commands.

Run Time

Mode Using HP-IB commands, the HP 85330A can be setup for a specific measurement sequence, then automatically execute that measurement (run-time mode).

Preparing the HP 85330A to Control the System

Configuring the HP 85330A is composed of the following steps:

1. Send the HP 85330A a series of HP-IB setup commands prior to starting the run-time sequence.
2. Start the run-time sequence by sending a specific HP-IB command.
3. The HP 85330A then waits for a positioner trigger signal to begin the sequence.
4. The HP 85330A repeats the sequence for the specified number of frequency points to be measured.

More detailed information on this subject is explained in Chapter 6, “Programming”.

Special Systems

Special system configurations allow you to:

- Daisy-Chain SCUs to provide many channels with a single multiple channel controller.
- Add remote multiple channel controllers to expand the switch tree or extend the physical distance that switches can be placed from the control room. Additional remote multiple channel controllers can be up to 2 Kilometers away from the master.

Switch Components

The HP 85330A controls the following items:

Switch control units

In standard systems, the system interface board communicates with one or two SCUs. SCUs perform the following tasks:

- They decode binary information from the multiple channel controller to determine which switch should be closed.
- They provide the necessary bias voltages to the switches, which causes them to switch states.

In a standard system, one SCU is connected to the multiple channel controller’s **PORT 1** connector, and the other SCU is connected to **PORT 2**. The separate ports provide the ability to put switches at the transmit and receive site.

PIN switch modules

The switches are broadband, high-isolation switches. Each switch is supplied with a switch control unit. Specifications and performance characteristics are provided in the *HP 85331A and HP 85332A PIN Switch User's Manual*.

The Downloadable Driver

The multiple channel controller cannot perform tasks until programming instructions are supplied. These instructions specify:

- How to interact with the control boards installed in its rear panel slots.
- The softkey menu interface and the functions performed by each softkey.
- The HP-IB programming commands that setup and control the multiple channel controller.

This driver is supplied by HP and is loaded into the multiple channel controller at the factory. If you must ever re-load the driver, refer to the instructions provided in Chapter 5, "Manual Operation".

System Interface

A system interface board (HP 85330-60002) is installed in the back of the multiple channel controller. This board contains the TTL trigger and ready lines that interface to the receiver, switch control units, and (if using Fast Source Control) the RF and LO sources.

Required Equipment

The following equipment is required in addition to the HP 85330A:

- The cables that connect the HP 85330A, switch control units and switch modules.
- One or more HP 85331A or HP 85332A PIN switch. The switches include their associated switch control unit.

Cables

HP 85383A Local Control Cable

Provides the connection between the multiple channel controller and each SCU. Cable length is determined at the time of order by selecting the appropriate length option.

- Option 002: 2 meters
- Option 005: 5 meters
- Option 010: 10 meters
- Option 020: 20 meters
- Option 030: 30 meters
- Option 040: 40 meters
- Option 050: 50 meters

Table 4-1 HP 85383 Wiring Table

D-Type Connector Pins	Circular Connector Pins	D-Type Connector Pins	Circular Connector Pins
1	A	14	K
2	C	15	R
3	B	16	S
4	D	17	X
5	E	18	T
6	L	19	Y
7	NC ¹	20	U
8	F	21	Z
9	M	22	V
10	H	23	a
11	N	24	W
12	J	25	b
13	P		

1. NC = No Connection

HP 85383B expansion cable

Allows SCU's to be daisy-chained together to create expanded switch matrices. Only 0.5 m cables are available.

HP 85384A Switch Driver Cable

Provides the connection between SCUs and switch modules. Cable length is determined at time of order by selecting the appropriate length option.

- Option 001: 1 meter
- Option 002: 2 meters
- Option 005: 5 meters
- Option 010: 10 meters

HP 85385A Remote Trigger Cable

Is a twisted-pair cable which allows you to connect a remote multiple channel controller. Cable lengths up to 2 Kilometers are available.

PIN Switches

The HP 85331A SP2T PIN Switch

The HP 85331A SP2T PIN switch consists of two modules:

- A switch control unit (SCU)
- A high-speed high-isolation SP2T microwave switch module

The HP 85332A SP4T PIN Switch

Identical to the HP 85331A except that the HP 85332A uses a SP4T switch module.

Supplied Equipment and Software

Table 4-2 *Supplied Equipment and Software*

Item	Quantity	Part or Model Number
Multiple channel controller	1	HP 85330A
Downloadable driver disk Rev A.03.00	1	85330-10016
Operating and Service Manual	1	85330-90019
E1301A/B Getting Started Guide	1	E1300-90004
E1302A User's Manual	1	E1300-90005
9-pin to 25-pin adapter	1	5181-6641
RS-232 Cable	1	HP 24542M
E1330A/B Users Manual	1	E1330-90004
ac power cord	1	Depends on Destination Country

HP 85330A Multiple Channel Controller Characteristics

This product is designed for use in Installation Category II and Pollution Degree 2 per IEC 1010 and 664 respectively.

CAUTION

Before switching on this instrument, make sure the line voltage selector switch is set to the voltage of the mains supply and the correct fuse is installed. Ensure the supply voltage is in the specified range.

Environmental Limits

Table 4-3 *Environmental Conditions for the HP 85330A*

Temperature:	
For Operation	+0 to +55 °C (32 to 131 °F)
For Storage	−40 to +70 °C (−40 to 158 °F)
Humidity:	
For Operation	5% to 95% at +40 °C or less (non condensing) 5% to 95% at +65 °C or less (non condensing)
Pressure Altitude:	
For Operation or Storage	Less than 4,600 meters (15,000 feet)
Power Requirements:	
Line Voltage	115 or 230 Vac 50 to 400 Hz
Fused at	3 A at 115 Vac 1.5 A at 230 Vac
Power Consumption:	
HP 85330A only	78 VA
HP 85330A + HP 85331A (all off)	88 VA
HP 85330A + HP 85332A (all off)	92 VA
HP 85330A + 2 HP 85332As (all off) ¹	107 VA

1. This is the worst case for a standard system.

Ventilation Requirements

CAUTION

When installing the product in a cabinet, the convection into and out of the product must not be restricted. The ambient temperature (outside the cabinet) must be less than the maximum operating temperature of the product by 4 °C for every 100 watts dissipated in the cabinet. If the total power dissipated in the cabinet is greater than 800 watts, then forced convection must be used.

Dimensions

Table 4-4 Size and Dimensions

Height without feet	177 mm	6.97 in
Height with feet	189 mm	7.44 in
Width	426 mm	16.75 in
Depth	510 mm	20.1 in
Depth with terminal blocks	569 mm	22.38 in
Net weight	≈ 11.8 kg	≈ 26 lbs

Front Panel Features

The front panel contains:

- A 2-line by 40 character display.
- A QWERTY keyboard, plus utility keys.
- Five software-controlled display softkeys.

Need More Information

Refer to the following locations for more information:

- Refer to Chapter 5, “Manual Operation” for more information. This chapter also describes the tasks you can perform manually with the HP 85330A.
- “Using the Front Panel” in the *HP 75000 Series B Mainframes User’s Manual*.

Rear Panel Features

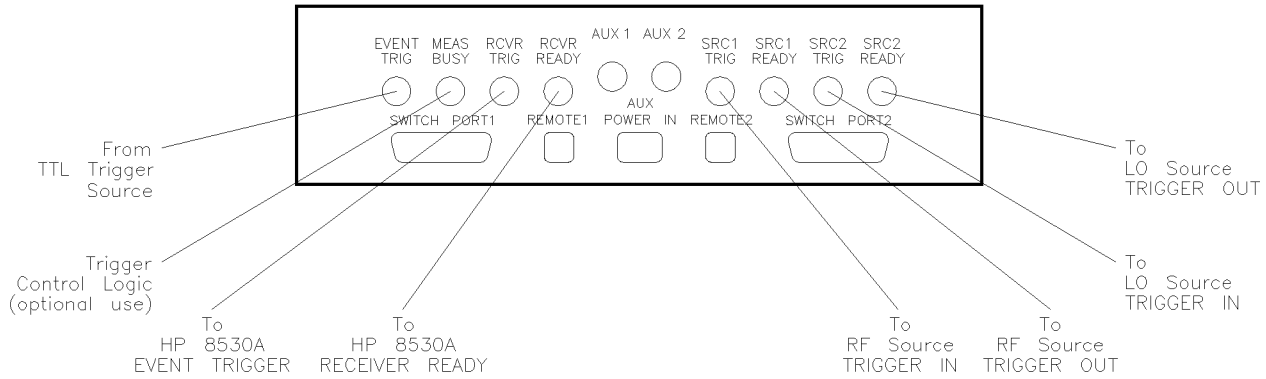

rear330

Figure 4-2 HP 85330A Rear Panel Connectors

EVENT TRIG

By default, this input accepts a positive or negative-edge TTL trigger from the positioner controller or other device. The default is positive-edge triggering. The trigger signal initiates a measurement sequence. Connect EVENT TRIG to the positioner controller or other TTL trigger source.

You can configure the HP 85330A so it responds to a negative-edge TTL trigger signal. Refer to Chapter 1, “Installation” for instructions.

MEAS BUSY

Goes TTL HIGH when the EVENT TRIG line is asserted. This line stays HIGH during the measurement sequence, going LOW after the measurement sequence is finished. This line is designed to tell external control logic when the measurement system is busy, and using it is optional.

RCVR TRIG

Sends a 2 to 3 μ s negative-edge pulse to the EVENT TRIGGER input of the receiver. This causes the receiver to acquire data. The number of parameters measured by a single trigger pulse is determined by how the receiver measurement controls are set up. A single parameter (radioed measurement point) is taken in the FASC, FASD, FASAD (Fast Data Acquisition) modes, and multiple parameters are measured if you are using the FASMUX mode.

The multiple channel controller may send several receiver trigger pulses during the measurement sequence, depending on the instructions you sent to it before starting the run-time mode.

RCVR READY

This positive-edge signal is sent by the receiver when it finished acquiring data. This line connects to the RECEIVER READY line on the receiver.

AUX 1

Provides a user-controllable TTL line for special applications. The state of AUX 1 must be set before entering the HP 85330A's automatic run-time mode. The state of AUX 1 is controlled with the ROUTe:CONTRol command.

AUX 2

Provides a user-controllable TTL line for special applications. The state of AUX 2 can be set in two ways:

- Before entering run-time mode using the ROUTe:CLOSe command.
- During run-time using RUNTime:SWITCh:SCAN command.

SRC 1 TRIG

Used in conjunction with SRC 1 READY, controls frequency switching in the RF source much faster than is possible under HP 8530A control. This connects to the TRIGGER IN line of the RF source.

SRC 1 READY

Used in conjunction with SRC 1 TRIG, controls frequency switching in the RF source much faster than is possible under HP 8530A control. This connects to the TRIGGER OUT line of the RF source.

SRC 2 TRIG

Used in conjunction with SRC 2 READY, controls frequency switching in the LO source much faster than is possible under HP 8530A control. This connects to the TRIGGER IN line of the LO source.

SRC 2 READY

Used in conjunction with SRC 2 TRIG, controls frequency switching in the LO source much faster than is possible under HP 8530A control. This connects to the TRIGGER OUT line of the LO source.

REMOTE 1 and 2

These connectors are used to add remote multiple channel controllers in custom systems, they are not used with the standard instrument.

SWITCH PORT 1 and 2

Connects to either of the two switch control units (SCUs). These ports provide binary data for switch control as well DC power.

AUX POWER IN

This connector is not used with the standard instrument.

HP 85330A Compatibility

Compatible Receivers

The HP 85330A is compatible with the HP 8530A microwave receiver.

Compatible LO Sources

Table 4-5 Required Options for HP 836xx LO Sources

Model Number	Recommended Options	Special Option Requirements
HP 83620A/B	008	HP 83620A's with a serial prefix less than 3103A require option H87. If cable length between the LO source and HP 85309A is greater than 7 meters, contact your local HP representative.
HP 83621A/B	None	HP 83621A's with a serial prefix less than 3103A require option H87.
HP 83622A/B	008	HP 83622A's with a serial prefix less than 3103A require option H87. If cable length between the LO source and HP 85309A is greater than 7 meters, contact your local HP representative.
HP 83623A/B	008	HP 83623A's with a serial prefix less than 3103A require option H87.
HP 83624A/B	008	HP 83624A's with a serial prefix less than 3103A require option H87.
HP 83630A/B	008	HP 83630A's with a serial prefix less than 3103A require option H87.
HP 83631A/B	None	HP 83630A's with a serial prefix less than 3103A require option H87.
HP 83640A/B	008	None
HP 83642A	008	None
HP 83650A/B	008	None
HP 83651A/B	None	None

Compatible RF Sources

Any HP 836xx series source is compatible.

General Information
HP 85330A Compatibility

5

Manual Operation

This chapter describes how to manually operate the HP 85330A multiple channel controller.

In This Chapter

- To use the front panel
- Softkey map
- To view or change the HP 85330A's HP-IB address
- To close any switch in the system (to select a channel)
- To change the TTL state of AUX 1 or AUX 2
- To view the most recent error message
- To view the revision of the downloaded driver
- To manually send triggers pulses
- To perform service functions

To Use the Front Panel

This is an overview of main front panel features. For more information, refer to “Using the Front Panel” in Chapter 2 of the *HP 75000 Series B Mainframes HP E1300A and E1301A/B User’s Manual*

The front panel contains:

- A 2-line by 40 character display
- A QWERTY keyboard, plus utility keys mentioned below
- Five software-controlled display softkeys

About the Softkeys Menus

The HP 85330A’s softkey menus behave differently than those in a network analyzer or microwave receiver. Each of the top level menu items *{SYSTEM}* *{85330A}* and *{IBASIC}* (IBASIC is present only if the IBASIC option is installed), are treated as if they were independent instrument personalities. When you leave a certain menu and return to it later, you start at the exact point you left off.

For example:

1. Press [Select Instr] *{85330A}* and press *{CLOSE}*.
2. Now, leave the 85330A menu by pressing [Select Instr] *{SYSTEM}*.
3. Return to the 85330A menu by pressing [Select Instr] *{85330A}*. Notice that the CLOSE function reappears, *not the top level of the 85330A menu*.

Utility Keys

[Select Instr]

This presents the two different instrument personalities, SYSTEM and HP 85330A. When you select an instrument, you are assigning the keyboard and display to that instrument. This means that any menu operations, commands executed or recalled, error displayed, etc. pertain only to that instrument. Front panel operation of an instrument is independent from other instruments and independent of the remote operation of the instrument.

[Prev Menu]

This key presents the previous softkey menu.

[More]

When there are more than five menu choices, an arrow appears on the right side of the display. Press [More] to display the next group of choices. This key also displays the next 40 characters in a long display message.

Softkey Map

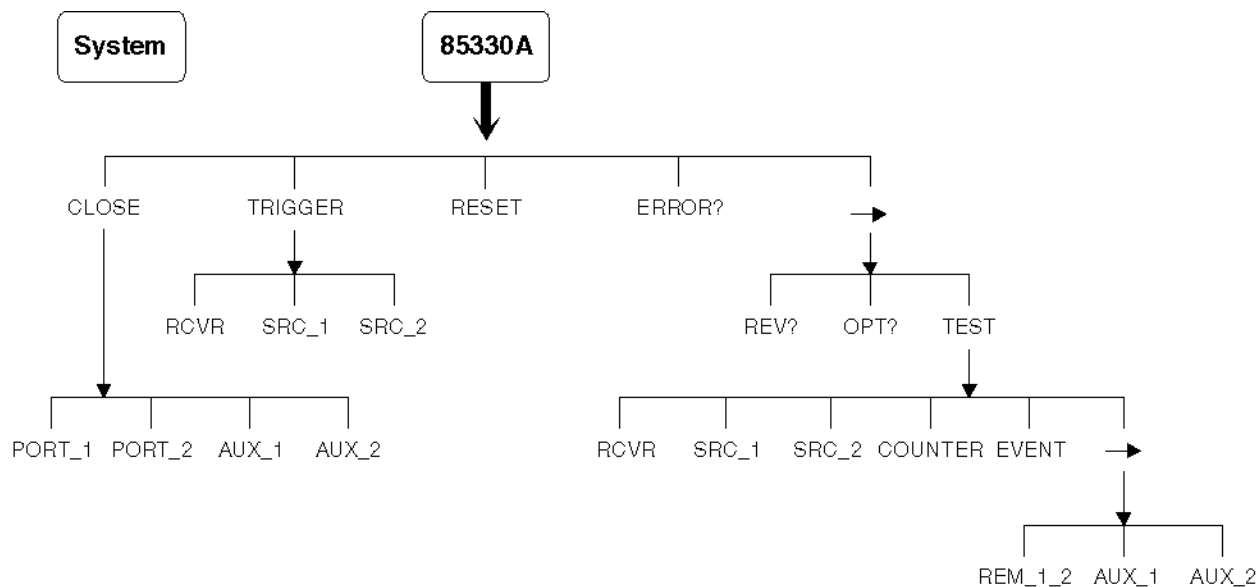

skeymap.cdr

Figure 5-1 HP 85330A Softkey Menu Map

NOTE

Refer to Chapter 3 of the *HP 75000 Series B Mainframes HP E1300A and E1301A/B User's Manual*.

To View or Change the HP 85330's HP-IB Address

Viewing HP-IB Address

The factory default setting of the HP-IB address is 9.

To view the HP-IB address:

Press:

[Select Instr] *{SYSTEM}* *{HP-IB}* *{READ}*

Changing the HP-IB Address

To change the current HP-IB address:

1. Press:

[Select Instr] *{SYSTEM}* *{HP-IB}* *{SET}*

2. Enter the new address and press:

[Return]

To Close Any Switch In the System (to select a channel)

To manually close a switch (to select a channel):

1. Press:
[Select Instr] {85330A}
2. If the {CLOSE} softkey does not appear, press:
[Prev Menu] (until it does)
3. Press:
{CLOSE}
 - a. If the switch you want to close is connected to PORT 1, press
{PORT_1}
 - b. If the switch you want to close is connected to PORT 2, press
{PORT_2}
4. Enter the switch address using the numeric keypad. In a standard system, simply enter the channel number (1, 2, 3, or 4), and press [Return].

More about Switch Addresses

The “switch address” is a concatenation of the Switch Control Unit (SCU) address (set to 0 at the factory) with the channel number (in “standard” systems this number is 1, 2, 3, or 4).

If you just enter the channel number (1, 2, 3, or 4), the multiple channel controller will assume that the SCU address is still at the factory default (0). Changing SCU address requires DIP switch changes inside the SCU, and is not necessary in standard systems. To select switch 1 (channel 1), just press [1] [Return].

In custom systems with many switches, a different SCU address might be used in part of the switch tree. Here are some example switch addresses for complex switch trees:

101 (SCU address 1, channel 01)

212 (SCU address 2, channel 12)

312 (SCU address 3, channel 12)

Notice in the first example (101) that a two digit channel number (01) was required. When the SCU address is set to 1, 2 or 3, you must enter a two-digit channel number – even for channels 1 through 9.

To Change the TTL State of AUX 1 or AUX 2

To set AUX 1 or AUX 2 TTL state:

1. Press:
[Select Instr] *{85330A}*
2. If the *{CLOSE}* softkey does not appear, press [Prev Menu] until it does.
3. Press:
{CLOSE}
4. Press:
{AUX_1} or *{AUX_2}*
5. Press *{0}* for TTL LOW or *{1}* for TTL HIGH.

To View the Most Recent Error Message

1. To view the most recent error message, press:
[Select Instr] *{85330A}*
2. If the { *ERROR?* } softkey does not appear, press
[Prev Menu] (until it does)
3. Press: { *ERROR?* }

To View the Revision of the Downloaded Driver

1. To view the revision of the downloaded driver, press:
[Select Instr] *{85330A}*
2. If the *{REV?}* softkey does not appear, press
[Prev Menu] (until it does)
3. Press: *{REV?}*
4. Press the [→] key to view the entire revision message.

To View Custom Option Number (If Applicable)

Some HP 85330A's are equipped with custom driver s as required by the customer. Pressing:

[Select Instr] then [More] the display will read:

Rev Opt? Test.

click on Opt?

This presents the custom option number (if any) for the driver.

To Manually Send Trigger Pulses

To manually issue a trigger to the receiver (EVENT TRIGGER), RF or LO source (TRIGGER IN):

1. Press:
 [Select Instr] *{85330A}*
2. If the *{TRIGGER}* softkey does not appear, press
 [Prev Menu] (until it does)
3. Press *{TRIGGER}*, followed by:
 {RCVR} to send a trigger to the receiver.
 {SRC_1} to send a trigger to the RF source.
 {SRC_2} to send a trigger to the LO source.

To Perform Service Functions

Service functions are located under the *{85330} {→} {TEST}* softkey menu. They are not described in this chapter. Refer to “Verifying the Multiple Channel Controller” on page 2-6 for more information.

6

Programming

In This Chapter

This chapter provides a general programming of the operation for the HP 85330A and a detailed description of the programming codes. Several scenarios and examples are given.

- HP-IB addresses
- Definition of terms
- To choose a measurement configuration
- To use Direct control
- To use run-time control mode
- Programming examples

HP-IB Addresses

Using HP-IB commands, the HP 85330A can be setup prior to run-time followed by an HP-IB command to pass run-time control to the HP 85330A. This is called **run-time control mode**. The HP 85330A can also directly control switch states and issue triggers using HP-IB commands. This is called **direct control**.

HP BASIC is used for all examples. To address the HP 85330A a secondary HP-IB address is needed. In most cases the complete HP-IB address would be 70918:

- “7” refers to the select code of the HP-IB address.
- “09” is the HP-IB address of the HP 85330A multiple channel controller.
- “18” is the secondary address of the E1330A/B DIO card. This is a board that is inside the multiple channel controller.

Long and Short Command Syntax

The HP-IB commands have a long and short form. The upper-case characters represent the short form and the complete set of characters represent the long form. Example, ROUTe:CLOSE is the complete or long form of the HP-IB command while the abbreviated or short form is ROUT:CLOS.

Definition of Terms

NOTE

Please review the following terms before reading information in this chapter.

SCU address

At the factory, each Switch Control Unit is assigned an address called an SCU address. When commands are sent out port 1 or port 2, they only affect SCUs with the specified SCU address. SCU addresses are set using DIP switches inside the SCU, and can be set to 0, 1, 2, or 3. In a standard system the factory default setting is 0. For custom-designed systems, refer to the documentation that came with that system for SCU address numbers. Daisy-chained SCUs may use the same SCU address.

Channel

Each switch module has either two or four possible switch positions, or channels. If you purchased a switching system designed by HP, you also have received a manual that applies specifically to that switch tree. That document shows the channel numbers for each switch. If you have purchased a “standard” system then channels 1 through 4 are the factory default channel numbers. (Channels 3 and 4 only apply to four-throw switches.)

NOTE

Ports 1 and 2 are addressed independently. Because of this, there are no addressing conflicts when using two SCUs – even if they use the same SCU address and channel numbers.

Switch address

This is the complete software address for a specific switch. It is simply a concatenation of the SCU address (0, 1, 2, or 3) with the channel number (usually 1, 2, 3, or 4, but possibly a number up to 64 in custom systems).

Examples:

@103 = SCU address 1 and channel 3 selected.

@2 = SCU address is 0 (and need not be specified), and channel 2 is selected.

@232 = SCU address is 2 and channel 32 is selected (custom systems only).

The port number (1 or 2) is specified separately, as is explained later in this chapter.

To Choose a Measurement Configuration

The measurement configuration you use depends on the type of measurement (CW or multiple-frequency) and the type of system (one-source or two-source system). One-source systems use the HP 8511A/B frequency converter, two-source systems use the HP 85309A frequency converter.

Refer to Figure 6-1.

How to Use the Figure

Follow the flow chart from the top. Determine if your measurements are made with a single frequency (CW), or multiple frequencies. Proceed down the appropriate flow chart path. Proceed in this way until you get to a box that mentions one of the following headings:

- CW Measurement Configuration
- Single Source Multiple-Frequency Configuration
- HP 8530A Control of Sources
- Fast Source Control

Proceed to the section indicated to read about that specific configuration.

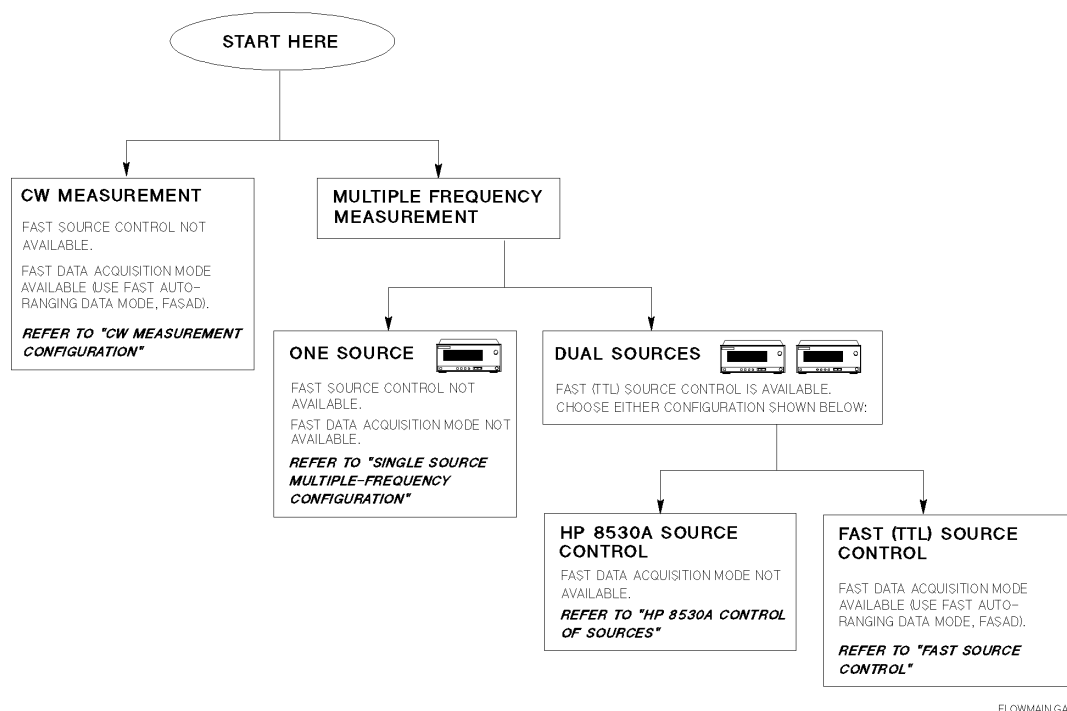

FLOWMAIN.GAL

Figure 6-1 Flow Chart for Finding the Correct Configuration

CW Measurement Configuration

Description

In single-frequency measurements the Fast Source Control mode is not used. The RF source (and LO source, if used) can either be controlled by:

- The HP 8530A (set the sources to Analyzer Language mode), or...
- The system computer (set the sources to SCPI Language mode).

Refer to the programming “Example 1” on page 6-21.

To Use this Configuration

The proper setup is shown in Figure 1-2 on page 1-4. Use the HP 8530A Fast Autoranging Data Mode (HP-IB command: *FASAD*), explained in Chapter 8 of the *HP 8530A User's Guide*.

Single Source Multiple-Frequency Configuration

Description

In single-source (HP 8511A/B based) systems, the Fast Source Control mode is *not* available. The RF source is controlled by the HP 8530A (Analyzer Language mode). The proper setup is shown in Figure 1-2 on page 1-4.

The Fast Data Acquisition modes of the HP 8530A cannot be used with this type of measurement. Instead, the multiple parameter display of the HP 8530A is used to measure each switch input.

Refer to the programming “Example 2” on page 6-24.

NOTE

When using the multiple parameter display feature, the minimum switch settling time (RUNT:SWIT:DEL) is 50 μ s. Using shorter settling times in multiple parameter display mode can cause measurement problems

To Use this Configuration

Here is an overview of how measurements are made in this configuration. Remember, HP-IB commands must be immediately followed by a semicolon when entered into an actual program. For example NUMEB1;

HP 8530A settings

- Select multiple parameter display mode on the HP 8530A. The number of parameters selected should equal the number of test signals you are measuring. For example, assume you have a two-throw **receive switch** connected to two test signals. In this case, program the HP 8530A for two parameter display HP-IB command TWOP. This is the equivalent of pressing [DISPLAY] {DISPLAY MODE} {TWO PARAMETER}.
- Set each parameter to measure the same input ratio. For example, set them all to measure $b1/a1$. The numerator and the denominator are defined below:
 - The numerator is the input port (of the frequency downconverter) that is connected to the common port of the receive switch. Set this using the HP-IB NUMEB1, NUMEB2, NUMEA1, or NUMEA2 command. This is equivalent to pressing PARAMETER {MENU} {REDEFINE PARAMETERS} {NUMERATOR}, then {NUMERATOR: b1}, {NUMERATOR: b2}, {NUMERATOR: a1}, or {NUMERATOR: a2}.
 - The denominator is the input port that is connected to the reference signal. Use the DENOA1, DENOA2, or DENOB1 command. This is equivalent to pressing PARAMETER {MENU} {REDEFINE PARAMETERS} {DENOMINATOR}, then {DENOM.: a1}, {DENOM.: a2}, or {DENOM.: b1}.

This setup allows the HP 8530A to measure each receive switch input in sequence. Each one is measured as a separate parameter, which you can read using the system computer. Refer to the HP-IB Programming chapter of the *HP 8530A Operating and Programming Manual* for detailed information.

- Select external triggering with TRGEXT. This is equivalent to pressing STIMULUS {MENU} {MORE} {TRIGGER MODE} {TRIG SRC EXTERNAL}. This command is described in the Stimulus chapter of the *HP 8530A Operating and Programming Manual*.
- Set the HP 8530A so it waits for a trigger before measuring each parameter. You can do this by issuing PAR1TON, PAR2TON, PAR3TON, and PAR4TON. This is equivalent to pressing STIMULUS {MENU} {MORE} {TRIGGER MODE}, then ensuring that {PARAM 1}, {PARAM 2}, {PARAM 3}, and {PARAM 4} are activated (underlined). These commands are described in the Stimulus chapter of the *HP 8530A Operating and Programming Manual*.

You only have to send the PARTON commands that relate to the parameters that are actually being measured. For example, if you are only measuring Parameter 1 and Parameter 2, PAR1TON and PAR2TON are the only two commands that must be executed.

NOTE

You can issue all four of these commands even if you are measuring only two or three parameters. The extra commands will simply be ignored.

HP 85330A settings

- When the source is under HP 8530A control, the multiple channel controller must be set to the IMMEDIATE triggering mode:
RUNT:SOUR:SOURCE1:TRIG IMM;
- Use HP-IB address 19 for the RF source.

Dual Source Multiple-Frequency Measurements

When you are using multiple-frequency measurements with an HP 85309A frequency converter, you can choose how the sources are controlled:

- You can allow the HP 8530A to control source frequency switching, or...
- You can use the Fast Source Control configuration, where source frequency switching is controlled by the multiple channel controller.

HP 8530A Control of Sources

Description

If you choose to control source frequency switching with the HP 8530A (and you are using the dual source multiple-frequency configuration) you cannot use the Fast Data Acquisition modes of the receiver. Refer to the programming “Example 2” on page 6-24.

To Use this Configuration

Operation in this mode is nearly identical to that described in “Single Source Multiple-Frequency Configuration” on page 6-5. When the sources are under HP 8530A control, the multiple channel controller must be set to the IMMEDIATE triggering mode:

```
RUNT:SOUR:SOURCE1:TRIG IMM;
```

```
RUNT:SOUR:SOURCE2:TRIG IMM;
```

Use HP-IB address 19 for the RF source, and 18 for the LO source.

Fast Source Control

Description

Fast source control *speeds up frequency switching speed* in multiple-frequency measurements. It is only available in HP 85309A-based systems. This mode uses TTL signals to increment RF and LO source frequency, providing faster frequency switching speeds than are possible under HP 8530A control.

Refer to the programming “Example 3” on page 6-27.

To Use this Configuration

In the fast source control configuration, the system’s computer must set up the sources with appropriate frequency settings, triggering mode, and so on. When automatic run-time measurement mode is engaged, the HP 85330A automatically increments the RF and LO source frequencies using TTL lines. When being controlled by a computer, the SCPI language mode must be selected. This is shown in Figure 1-3 on page 1-5.

Fast Data Acquisition can be used in this configuration. Use the HP 8530A Fast Autoranging Data Mode (HP-IB command: **FASAD**), as explained in Chapter 8 of the *HP 8530A User’s Guide*.

HP 8530A settings

In the HP 8530A Local menu, the addresses for Source 1 and Source 2 must be set to 31. This tells the HP 8530A that it cannot communicate with the sources.

HP 85330A settings

Since the HP 8530A does not control the sources, set the multiple channel controller to TTL triggering mode:

```
RUNT:SOUR:SOURCE1:TRIG TTL;
```

```
RUNT:SOUR:SOURCE2:TRIG TTL;
```

Source settings

- Use Frequency List or Step mode.
- Sweep Point Trigger must be set to EXT:

```
SWE:TRIG:SOUR EXT;
```
- Start Sweep Trigger must be set to AUTO:

```
TRIG:SOUR IMM;
```

The Sweep Point Trigger and Start Sweep Trigger settings allow external triggers from the HP 85330A to trigger the sources.

To Use Direct Control

Direct control is where the host computer issues HP-IB commands and the HP 85330A executes them immediately. For example, the `ROUT:CLOSe (port number) (switch address)` command causes the HP 85330A to immediately change switch states.

Selecting a Channel

Here are examples of how to select a channel.

Example 1, for a standard system

`OUTPUT 70918; "ROUT:CLOS 1,(@2);"`

Switch port 1, default SCU address (0), channel 2 selected.

In this example, the HP BASIC `OUTPUT` command is used to output a command to the HP 85330A. The command, `ROUT:CLOS 1,(@2);` is sent to HP-IB address 70918 (the HP 85330A). This command string would:

- Activate switch port 1.
- Address the SCU (which is set at the factory to SCU address 0). Since the default address is being used, the SCU address is not required, and is not specified in the command.
- Select channel 2.

Example 2, for a typical custom system

`OUTPUT 70918; "ROUT:CLOS 2,(@110);"`

Switch port 2, SCU address 1, channel 10

The command, `ROUT:CLOS 2,(@110);` is sent to HP-IB address 70918 (the HP 85330A). This command string would:

- Activate switch port 2.
- Address any SCU, or SCUs, at SCU address 1.
- Select channel 10. "110" is the switch address and is defined as the concatenation of the SCU address and the channel number.

Other examples:

```
OUTPUT 70918;"ROUT:CLOS 2,@103;"  
Switch Port 2, SCU address 1, channel 3.
```

```
OUTPUT 70918;"ROUT:CLOS 1,@2;"  
Switch Port 1, SCU address 0, channel 2.
```

```
OUTPUT 70918;"ROUT:CLOS 1,@132;"  
Switch Port 1, SCU address 1, channel 32.
```

Sending multiple switch addresses is possible. In the following example:

- An example is provided for standard systems (SCU address 0).
- An example is provided for a typical custom system, with an SCU address of 1.

Both examples select channel 1, 2 and 3 in sequence.

NOTE

Because the switches are SP2T's or SP4T's, when a channel on a module is closed all other channels on that module are open. For example, when 1 is closed, 2, 3 and 4 are open; when 2 is closed, 1, 3, and 4 are open.

```
OUTPUT 70918;"ROUT:CLOS 1,@1,2,3;"  
example for standard systems
```

```
OUTPUT 70918;"ROUT:CLOS 1,@101,102,103;"  
example for custom systems
```

Another method of executing the above command is

```
OUTPUT 70918;"ROUT:CLOS 1,@1:3;"  
example for standard systems
```

```
OUTPUT 70918;"ROUT:CLOS 1,@101:103;"  
example for custom systems
```

The colon : represents 1 *through* 3 (or 101 *through* 103).

To set a delay between the closing of each switch state the ROUTe:DELAy command is used. The input parameter is time in micro-seconds.

```
10 OUTPUT 70918;"*RST;"  
Reset the HP 85330A.
```

```
20 OUTPUT 70918;"ROUT:DELA 10000;"  
Set the time between switch states in micro-seconds.
```

```
30 OUTPUT 70918;"ROUT:CLOS 1,@101:104;"  
Close switch state 101 through 104.
```

To Use Direct Control

In this example:

- The HP 85330A is reset using the *RST command.
- A delay between switch states is specified.
- Channels 101, 102, 103 and 104 are selected in sequence.

To Use Run-Time Control Mode

Setup of the HP 85330A Multiple Channel Controller

The setup for run-time operation includes setting:

- The event triggering method
- The number of frequency points
- The number of angular increments
- List of switch states
- Switch settling time
- TTL trigger and ready timeouts
- Using more than one controller

Once the HP 85330A is setup, send the `RUNT:INIT:IMM` command to begin run-time operation. Figure 6-2 on page 6-16 is a flow chart that illustrates the run-time measurement sequence. Commands are described in Chapter 7, “Remote Programming Command Reference”.

Event Triggering

During run-time operation, the HP 85330A may use two different types of event triggering, TTL or IMM. Most angle scan measurements will be set up for TTL triggering, while TTL triggering can be suppressed for a frequency response measurement, typically at a single angle. Also, this IMM mode combined with the `*OPC?` command is useful for determining timing information of a multiple-frequency, multi-parameter measurement.

Applicable command: `RUNTime:EVENTe:TRIGger`

Number of Frequency Points

The HP 85330A does not require a start, stop, or frequency step size. In fact, it does not require any frequency *values*. It only needs to know the number of frequency points so it can issue the correct number of triggers.

Applicable command: `RUNTime:SOURce:COUNT`

Number of Angular Increments (Events)

The HP 85330A does not require any angular *values*. It only requires the number of angular increments so it can issue the correct number of triggers.

Applicable command: `RUNTime:EVENTt:COUNT`

List of Switch States

One must set up the list of channel addresses for the measurement. For each event trigger received by the HP 85330A, each channel address entry will be asserted and a subsequent trigger issued to begin a measurement of each data point.

Applicable command: `RUNTime:SWITCh:SCAN`

To Use Run-Time Control Mode

Switch Settling Time

You must specify switch settling time before starting run-time mode. The default setting is 2 μ s.

NOTE

If your configuration requires you to use the multiple-parameter display features of the HP 8530A, as described in “Single Source Multiple-Frequency Configuration” on page 6-5, set settling time to 50 μ s. This applies to:

- The single source multiple-frequency configuration.
- The dual source multiple-frequency configuration, *but only when the HP 8530A controls the sources.*

Applicable command: `RUNTime:SWITCh:DELay`

TTL Trigger and Ready Timeouts

Timeout conditions are used for:

- Event triggering (EVENT TRIG)
- Receiver ready (RCVR READY)
- Source ready lines (SRC 1 READY and SRC 2 READY)

Timeouts enable the HP 85330A to recover from possible error conditions.

The timeout for the *event trigger input* has two separate timeout settings:

- One timeout is for the first trigger being issued.
- The other timeout is for subsequent triggers.

If the expected signal is not received before the specified time, the HP 85330A will exit from run-time operation and issue an error.

Applicable commands:

- `RUNTime:TIMEout:EVENT`
- `RUNTime:TIMEout:RECeiver`
- `RUNTime:TIMEout:SOURce`

Using More than One Controller

More than one multiple channel controller may be used in a system. Multiple controllers are usually used when the distance to a switch control unit exceeds the maximum length allowed. The REMOTE 1 and REMOTE 2 connectors on the rear panel allow connections to multiple controllers. See Chapter 9, “Service” for more information on these connectors.

To set up and control the remote controller, use these commands:

- RUNTime:CONTRoller
- RUNTime:TIMEout:REMOte
- RUNTime:SWITCh:TRIGger

The remote controllers can be triggered using the commands:

- RUNTime:SOURce:SOURCE1:TRIGger
- RUNTime:SOURce:SOURCE2:TRIGger

Starting Run-Time Mode

Issue the RUNT:INIT:IMM command to initiate the run-time operation. This command passes the hardware control to the HP 85330A and allows it to accept and issue triggers.

```
OUTPUT 70918;"RUNT:INIT:IMM;"
```

Once the sequence is initiated the HP 85330A either:

- Waits for an event trigger before issuing a trigger to the receiver, or:
- Immediately issues a trigger to the receiver.

This is set using the RUNT:EVEN:TRIG command.

Run-Time Measurement Sequence

Refer to Figure 6-2 on page 6-16. The chart shows the sequence of a run-time measurement. Programming commands applicable to each function are shown. All programming commands must be executed *before* run-time is initiated. Here is a description of the run-time measurement sequence:

Idle

This is the idle state of the HP 85330A. This also the state the unit enters if an error occurs during run-time. Run-time mode is started when RUNT:INIT:IMM is executed.

Select Switch State

The first switch state is selected for Port 1 or Port 2, as defined with the RUNT:SWIT:SCAN command. A delay now occurs to allow the switch to settle, defined with RUNT:SWIT:DEL.

To Use Run-Time Control Mode

Event Trigger

If TTL triggering has been selected, the HP 85330A waits for an Event Trigger pulse before sending a measurement trigger to the receiver. If IMM triggering has been selected, the measurement trigger is sent to the receiver immediately. The trigger mode is selected using `RUNT:EVENT:TRIG`. If a timeout occurs while waiting for Event Trigger, run-time is aborted and an error message is issued. The timeout duration can be set using the `RUNT:TIME:EVEN` command.

Receiver Ready

The HP 85330A now waits for the Receiver Ready signal (from the receiver), indicating that the HP 8530A is ready to take another measurement. If a timeout occurs while waiting for Receiver Ready, run-time is aborted and an error message is issued. The timeout duration can be set using the `RUNT:TIME:REC` command.

Switch List Loop

If all switch settings defined in `RUNT:SWIT:SCAN` have *not* been measured, the next switch state is asserted and the settling time delay occurs. Another measurement trigger is sent to the receiver, and the HP 85330A waits for Receiver Ready again. This loop continues until all defined switch states have been measured.

Programming
To Use Run-Time Control Mode

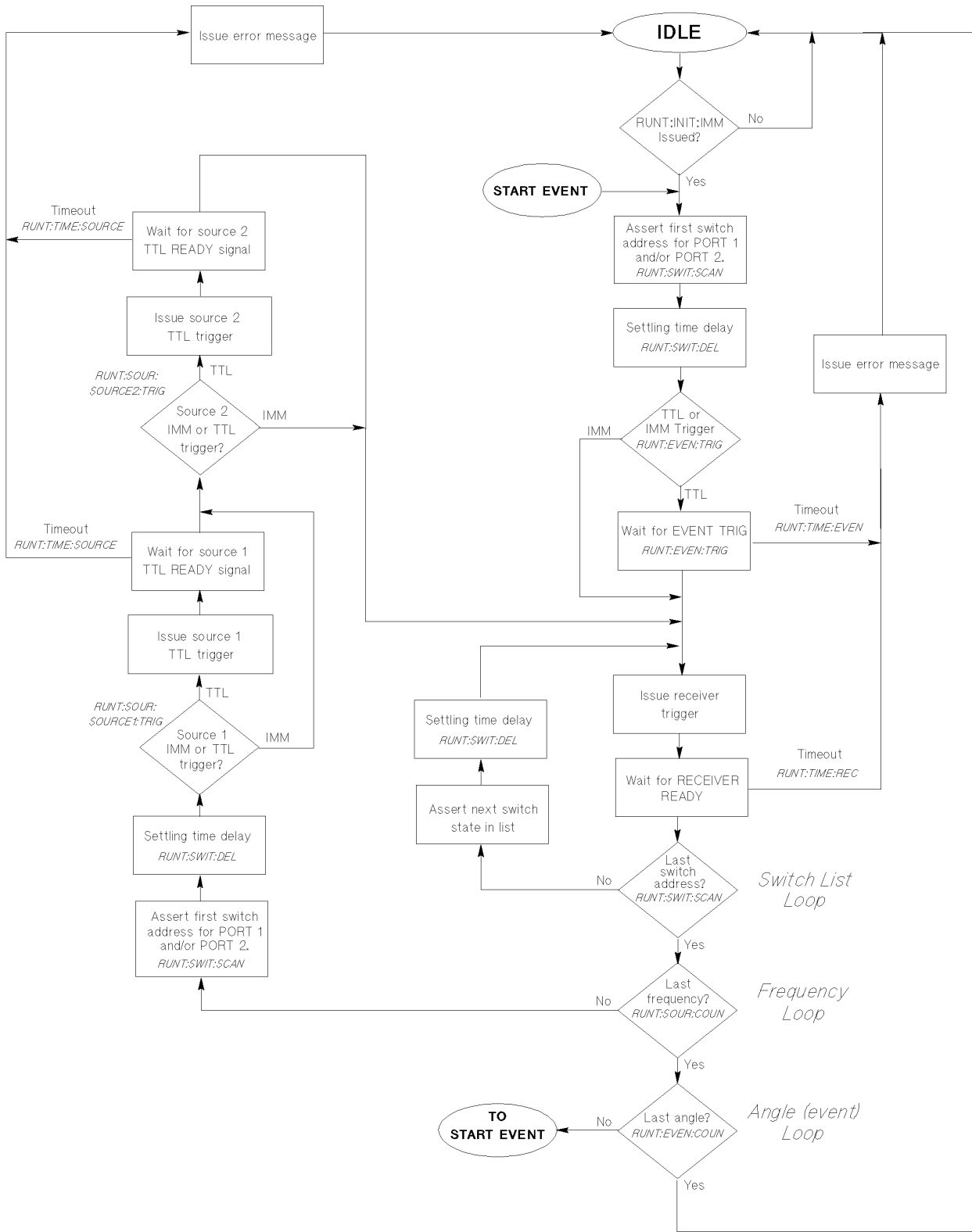

Figure 6-2 Run-Time Flow Chart with Programming Command References

To Use Run-Time Control Mode

Frequency Loop

After all switch states have been measured *at the first frequency*, the measurements can now be repeated at the next frequency. Here are the steps that occur during the frequency change:

- The first switch state is asserted once more, and the settling time delay occurs.
- If source 1 triggering is set to TTL (applicable for fast source control mode), a frequency-incrementing trigger is sent to source 1, and the HP 85330A waits for the TTL Ready signal before continuing. If a timeout occurs while waiting for TTL Ready, run-time is aborted and an error message is issued. The timeout duration can be set using the **RUNT:TIME:SOUR** command. When TTL Ready is received, the HP 85330A checks the triggering mode of source 2.

If source 1 triggering is set to IMM (applicable for measurements where the sources are controlled by the HP 8530A), the HP 85330A immediately checks the triggering mode of source 2.

- If source 2 triggering is set to TTL (applicable for fast source control mode), a frequency-incrementing trigger is sent to source 2, and the HP 85330A waits for the TTL Ready signal before continuing. If a timeout occurs while waiting for TTL Ready, run-time is aborted and an error message is issued. The timeout duration can be set using the HP 85330A **RUNT:TIME:SOUR** command. When TTL Ready is received, the HP 85330A re-enters the Switch List Loop so all switch states will be measured at the new frequency.

If source 2 triggering is set to IMM (applicable to measurements where the sources are controlled by the HP 8530A), the HP 85330A immediately re-enters the Switch List Loop so all switch states will be measured at the new frequency.

Event Loop

Once all switch states have been measured at all frequencies, the next “event” can be measured. This would be the next angle in an antenna measurement system. Stated generically, this is a full repetition of measurements at all switch states and frequencies for the next “event.” An “event” being whatever has occurred that caused another Event Trigger signal. The number of events in the measurement is defined using the **RUNT:EVENT:COUN** command.

The sequence now loops back to START EVENT, which is at the beginning of the event loop. The event loop repeats, measuring all switch states at each frequency until the number of event loops is completed. When finished, the HP 85330A exits run-time mode and goes into the idle state.

Run-Time Measurement Sequence for Multiple Controllers

The run-time measurement sequence for multiple controllers is similar to a single controller shown earlier. See “Starting Run-Time Mode” on page 6-14 for more information on this sequence. The sequence for multiple controllers has additional steps to allow communications between the controllers. Refer to Figure 6-3 on page 6-19 and Figure 6-4 on page 6-20 for the actual run-time measurement sequence.

Using IMM vs. TTL Trigger for Source 1

Refer to “Source 1 IMM, TTL or REM1 trigger diamond in Figure 6-3 on page 6-19.

When using multi frequencies:

- The RF Source controlled by the master HP 85330A should use the TTL trigger.
- The other RF Source (not controlled by the master HP 85330A) should use the IMM trigger.

To Use Run-Time Control Mode

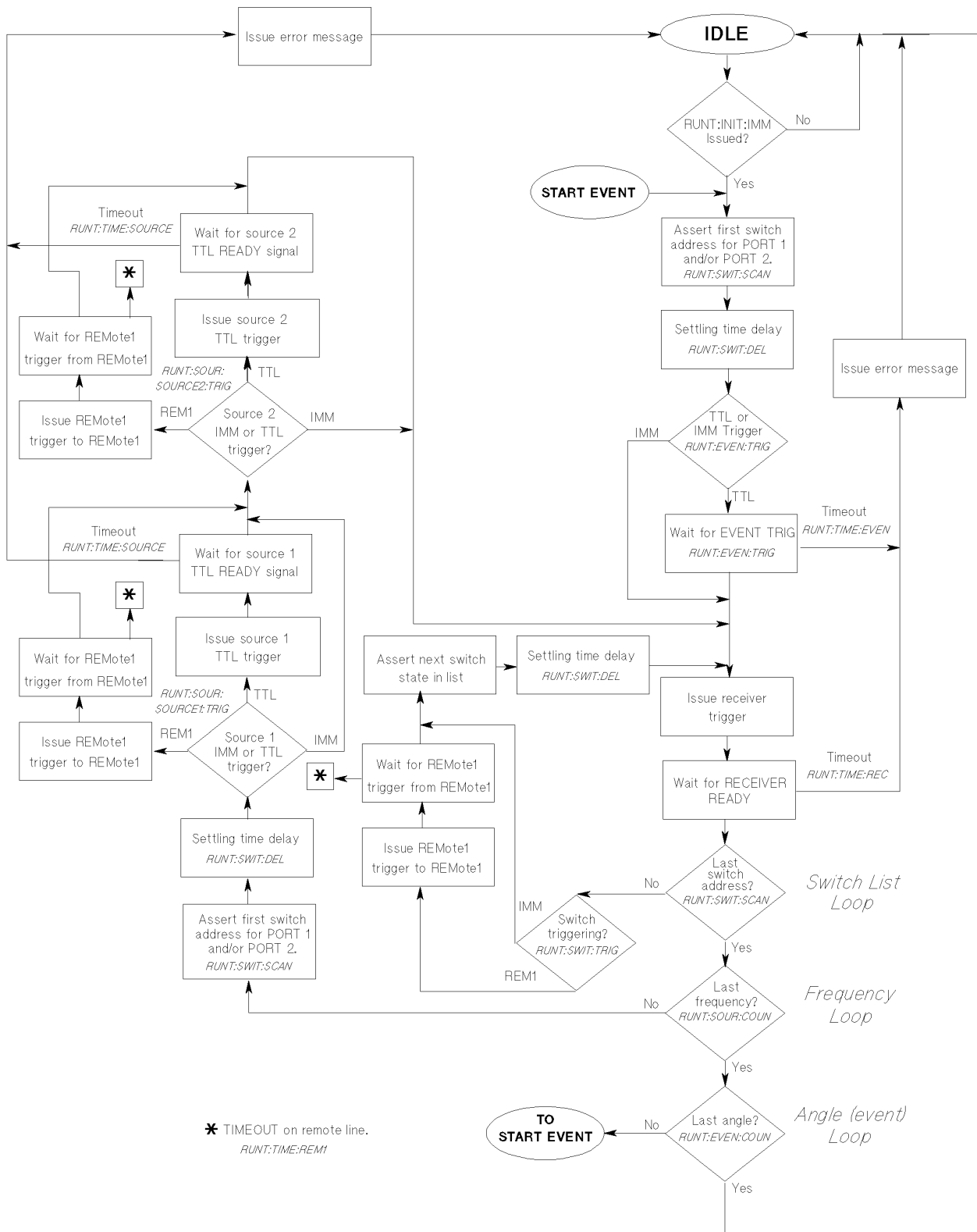

Figure 6-3 Run-Time Flow Chart for Multiple Controller, Control Mode controlling REMote1

Programming
To Use Run-Time Control Mode

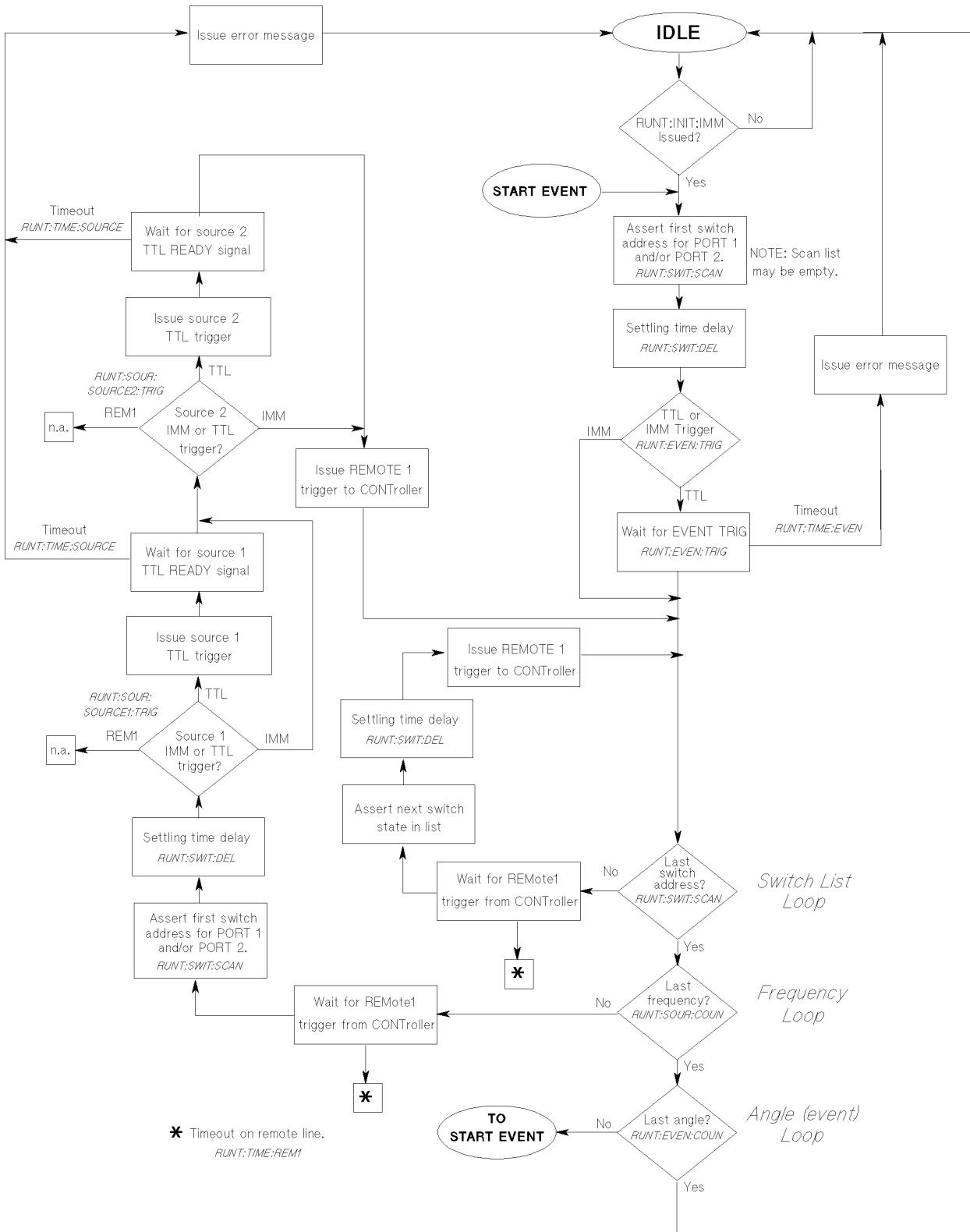

Figure 6-4 Run-Time Flow Chart for Multiple Controller, Remote Mode being controlled by CONTroller

Programming Examples

Example 1

Example 1 is applicable to CW measurements.

```

1001  !
1002  !RE--SAVE "EXAMPLE_1.rmb"
1003  !
1004  Example_1:!
1005  !
1006  ! This example shows how to make single-frequency, multi-channel
1007  !measurements using the HP 85330A and the FAST DATA modes of the HP 8530A
1008  ! Microwave Receiver.
1009  !
1010  ! It uses the HP BASIC/WS TRANSFER command to read data from the receiver.
1011  ! The HP BASIC command ENTER may also be used.
1012  !
1013  INTEGER Data_f1(1:32000,0:2) BUFFER ! DATA FROM RECEIVER IN FORMAT FORM1.
1014  DIM Err_str$(128)
1015  !
1016  Build_table:!
1017  !
1018  ALLOCATE REAL Exp_tbl(0:255)
1019  !
1020  ! Build the FORM1 to FORM3 coversion table. During the FAST DATA
1021  ! aquisition from the HP 8530A data translation is need to conver the
1022  ! 6 bytes read from the receiver to a data point consiting of a
1023  ! real and imaginary pair.
1024  !
1025  Exp_tbl(0)=2^(-15)
1026  FOR N=0 TO 126
1027     Exp_tbl(N+1)=Exp_tbl(N)+Exp_tbl(N)
1028  NEXT N
1029  Exp_tbl(128)=2^(-143)
1030  FOR N=128 TO 254
1031     Exp_tbl(N+1)=Exp_tbl(N)+Exp_tbl(N)
1032  NEXT N
1033  !
1034  Set_vars:!
1035  !
1036  ! Set variables
1037  !
1038  Scu_addr=0           ! SCU address
1039  Chan_start=1        ! First Channel
1040  Chan_stop=4         ! Last Channel
1041  Chan_pts=(Chan_stop-Chan_start)+1 ! Number of channels
1042  Switch_start=Scu_addr*100+Chan_start ! Starting SWITCH ADDRESS
1043  Switch_stop=Scu_addr*100+Chan_stop  ! Ending SWITCH ADDRESS
1044  !
1045  Angle_start=-90
1046  Angle_stop=90
1047  Angle_incr=10
1048  Angle_pts=((Angle_stop-Angle_start)/Angle_incr)+1
1049  !
1050  Freq_cw=2 ! GHz

```

Programming
Programming Examples

```
1051  !
1052  Rec_averages=1
1053  !
1054  Points=Angle_pts*Chan_pts  ! Total points to be taken.
1055  !
1056  REDIM Data_f1(1:Points,0:2)  ! Re-dimension array to the number of points.
1057  ALLOCATE Data_f3(1:Points,1:2) ! Converted data in FORM3 (REAL AND IMAGINARY
1058  !                               ! PAIRS).
1059  !
1060  ! Set HP-IB addresses
1061  !
1062  ASSIGN @Rec TO 716           ! ASSIGN 8530A HP-IB.
1063  ASSIGN @Rec_data TO 716;FORMAT OFF  ! ASSIGN 8530A DATA HP-IB.
1064  ASSIGN @hp85330a TO 70918      ! ASSIGN 85330A HP-IB
1065  ASSIGN @Buffer TO BUFFER Data_f1(*) ! ASSIGN input BUFFER for TRANFER
1066  !                               ! statement.
1067  Set_receiver:!
1068  !
1069  OUTPUT @Rec;"FREQ;"           ! Set to frequency domain
1070  OUTPUT @Rec;"SINC;"          ! Set to single channel
1071  OUTPUT @Rec;"SINP;"         ! Set to single point
1072  OUTPUT @Rec;"CENT ";Freq_cw;"GHZ;" ! Set to single point
1073  OUTPUT @Rec;"PARA1;"        ! select b1/a1 ratio
1074  !
1075  IF Rec_averages>1 THEN
1076  OUTPUT @Rec;"AVERON";Rec_averages;" " ! Turn averaging on.
1077  ELSE
1078  OUTPUT @Rec;"AVEROFF;"        ! Turn averaging off.
1079  END IF
1080  !
1081  !
1082  Set_85330a:!
1083  !
1084  OUTPUT @Hp85330a;"*RST;"      ! Reset
1085  OUTPUT @hp85330a;"RUNT:EVEN:TRIG TTL;" ! Set the triggering.
1086  OUTPUT @hp85330a;"RUNT:EVEN:COUN ";Angle_pts;" " ! Angle increments
1087  !
1088  OUTPUT @hp85330a;"RUNT:TIME:EVEN 0,15000000;" ! timeout 1st point: 15 sec.
1089  OUTPUT @hp85330a;"RUNT:TIME:EVEN 1,5000000;" ! timeout 2nd - last: 5 sec.
1090  OUTPUT @hp85330a;"RUNT:TIME:REC 1000000;" ! timeout receiver: 1 sec.
1091  !
1092  OUTPUT @hp85330a;"RUNT:SWIT:DEL 2;" ! Switch settling is 2 uS.
1093  OUTPUT @hp85330a;"RUNT:SWIT:SCAN 1,(@";Switch_start;" " " ;Switch_stop;" " );"
1094  !
1095  OUTPUT @hp85330a;"RUNT:SOUR:COUN 1;" ! Frequency points = 1 for CW
1096  OUTPUT @hp85330a;"RUNT:SOUR:SOURCE1 :TRIG IMM;" ! No External triggering.
1097  OUTPUT @hp85330a;"RUNT:SOUR:SOURCE2:TRIG IMM;" ! No External triggering.
1098  !
1099  OUTPUT @Hp85330a;"SYST:ERR?;" ! Check error status
1100  ENTER @Hp85330a;Err_num,Err_str$ !
1101  !
1102  Set_positioner:!
1103  !
1104  ! Set positioner to start angle.
1105  ! Set velocity, acceleration.
1106  ! Set start, stop and increment angles.
1107  !
1108  Start_meas:!
1109  !
1110  ! Set the HP 8530A in FAST AUTO-RANGING data mode.
```

Programming Examples

```

1111      !
1112      OUTPUT @Rec;"FASAD;"           ! SET THE RECEIVER TO FAST DATA w/ AUTO-RANGE.
1113      REPEAT                         ! WAIT UNTIL THE RECEIVER IS READY TO
1114      WAIT .001                       ! TO TAKE DATA.
1115      UNTIL BIT(SPOLL(@Rec),2)        !
1116      TRIGGER @Rec                    ! ISSUE HPIB TRIGGER TO BEGIN FAST DATA MODE.
1117      !
1118      ! Set the HP 85330A to intitiate the run time control.
1119      !
1120      OUTPUT @Hp85330a;"RUNT:INIT:IMM;" ! Initiate the HP 85330A run time mode.
1121      !
1122      ! Set the positioner to take an angle scan.
1123      !
1124      REM Start the positioner.
1125      !
1126      ! This starts the data tranfer from the receiver to the computer. When
1127      ! a trigger is issued to the receiver the data is placed into the receiver's
1128      ! buffer and then read from the reciever using the following TRANSFER
1129      ! statement.
1130      !
1131      TRANSFER @Rec TO @Buffer;RECORDS Points,EOR (COUNT 6)
1132      !
1133      N=1                               ! N IS THE CURRENT POINT.
1134      REPEAT
1135      !
1136      ! The TRANFER statement is a background process that allows the
1137      ! computer BUFFER to be filled while the other commands are executed.
1138      ! Therefore, other code (i.e. drawing data to the display data can go
1139      ! here without hindering the measurement process.
1140      !
1141      ! The ENTER statement can also be used to read part or all of the trace
1142      ! instead of using the TRANFER statement.
1143      !
1144      ! Remember that in FORM 1 data, which the HP 8530A uses in the FAST DATA
1145      ! modes each data point is 6 bytes. The 6 bytes must be converted to
1146      ! a real and imaginary pair.
1147      !
1148      ! --
1149      !
1150      STATUS @Buffer,4:R4               ! Check the number of bytes in the buffer
1151      IF R4>=6*N THEN                   ! Is there another point (6 bytes) in the buffer?
1152      !
1153      ! If yes THEN converte the data from FORM 1.
1154      !
1155      Exp=Exp_tbl(BINAND(Data_f1(N,2),255))! CONVERT FORM1 TO FORM3.
1156      Data_f3(N,1)=Data_f1(N,1)*Exp     ! REAL DATA.
1157      Data_f3(N,2)=Data_f1(N,0)*Exp     ! IMAGINARY DATA.
1158      N=N+1
1159      END IF
1160      !
1161      UNTIL N>Points
1162      !
1163      CONTROL @Buffer,8;0                ! TERMINATE TRANSFER
1164      OUTPUT @Rec;"SINP;"               ! TAKE RECEIVER OUT OF FAST-CW  MODE
1165      END

```

Example 2

Example 2 applies to measurements where the sources are controlled by the HP 8530A.

```
1001  !
1002  ! RE-SAVE "EXAMPLE_2.rmb"
1003  !
1004  Example_2: !
1005  !
1006  ! This example shows how to use the HP 85330A and HP 8530A's Multi-parameter
1007  ! Display mode. This is used for multi-frequency measurements when the
1008  ! microwave sources are under HP 8530A HP-IB control.
1009  !
1010  ASSIGN @Rec TO 716                ! ASSIGN 8530A HP-IB.
1011  ASSIGN @Rec_data TO 716;FORMAT OFF ! ASSIGN 8530A DATA HP-IB.
1012  ASSIGN @hp85330a TO 70918        ! Assign 85330A HP-IB
1013  !
1014  DIM Outstr$(128)
1015  DIM Err_str$(128)
1016  !
1017  Scu_addr=0                        ! SCU address
1018  Chan_start=1                      ! First Channel
1019  Chan_stop=4                       ! Last Channel
1020  Chan_pts=(Chan_stop-Chan_start)+1 ! Number of channels
1021  Switch_start=Scu_addr*100+Chan_start ! Starting SWITCH ADDRESS
1022  Switch_stop=Scu_addr*100+Chan_stop  ! STOPPING SWITCH ADDRESS
1023  !
1024  Angle_start=-90
1025  Angle_stop=90
1026  Angle_incr=10
1027  Angle_pts=((Angle_stop-Angle_start)/Angle_incr)+1
1028  !
1029  Freq_start=2
1030  Freq_stop=20
1031  Freq_pts=5
1032  !
1033  Rec_averages=1
1034  !
1035  Set_receiver: !
1036  !
1037  INTEGER Preamble,Data_bytes
1038  ALLOCATE REAL Data_freq(1:Freq_pts,1:2)
1039  !
1040  OUTPUT @Rec;"FREQ;"                ! FREQUENCY DOMAIN.
1041  OUTPUT @Rec;"EDITLIST;CLEL;SADD;"  ! Edit FREQ LIST.
1042  OUTPUT @Rec;"STAR";Freq_start;" GHZ;STOP";Freq_stop;"GHZ;" ! Set Start, stop.
1043  OUTPUT @Rec;"POIN";Freq_pts;" ;SDON;EDITDONE;"           ! Set points.
1044  1044 OUTPUT @Rec;"LISFREQ;"        ! Turn on FREQ LIST.
1045  !
1046  IF Rec_averages>1 THEN
1047  OUTPUT @Rec;"AVERON";Rec_averages;" " ! Turn averaging on.
1048  ELSE
1049  OUTPUT @Rec;"AVEROFF;"              ! Turn averaging off.
1050  END IF
1051  !
1052  ! MULTI-PARAMETER display only uses trigger if parameter is active.
1053  !
1054  1054 OUTPUT @Rec;"STITOFF;" ! STIMULUS TRIGGER OFF
1055  1056 OUTPUT @Rec;"PAR2TON;" ! PARAMETER 2 TRIGGER ON
```

Programming Examples

```

1056 OUTPUT @Rec;"PAR2TON;"! PARAMETER 2 TRIGGER ON
1057 OUTPUT @Rec;"PAR3TON;"! PARAMETER 3 TRIGGER ON
1058 OUTPUT @Rec;"PAR4TON;"! PARAMETER 4 TRIGGER ON
1059 !
1060 ! Set all ratios for each displayed parameter to a common channel
1061 !
1062 OUTPUT @Rec;"PARA1;NUMEB1;DENOA1;LOCKNONE;DRIVNONE;REDD;" ! b1/a1 ratio
1063 OUTPUT @Rec;"PARA2;NUMEB1;DENOA1;LOCKNONE;DRIVNONE;REDD;" ! b1/a1 ratio
1064 OUTPUT @Rec;"PARA3;NUMEB1;DENOA1;LOCKNONE;DRIVNONE;REDD;" ! b1/a1 ratio
1065 OUTPUT @Rec;"PARA4;NUMEB1;DENOA1;LOCKNONE;DRIVNONE;REDD;" ! b1/a1 ratio
1066 !
1067 ! Set the active channels using the MULTI-PARAMETER display.
1068 !
1069 IF Chan_pts=1 THEN OUTPUT @Rec;"SINC;"
1070 IF Chan_pts=2 THEN OUTPUT @Rec;"TWOP;"
1071 IF Chan_pts=3 THEN OUTPUT @Rec;"THREEP;"
1072 IF Chan_pts=4 THEN OUTPUT @Rec;"FOURP;"
1073 !
1074 ! The first pass of a frequency sweep for the HP 8360A source is slower than
1075 ! subsequent sweeps, since the source is in learn mode. Take one slow one,
1076 ! then one fast one.
1077 !
1078 FOR Passes=1 TO 2 ! Take two passes: one slow, one fast.
1079 OUTPUT @Rec;"TRGSFRE;HOLD;" ! Use internal triggering for these sweeps.
1080 OUTPUT @Rec;"SING;" ! take a single sweep.
1081 FOR N=1 TO Chan_pts
1082 OUTPUT @Rec;"PARA"&&VAL$(N)&";"
1083 OUTPUT @Rec;"FORM3;OUTPDATA;"
1084 ENTER @Rec_data;Preamble,Data_bytes
1085 ENTER @Rec_data;Data_freq(*)
1086 NEXT N
1087 NEXT Passes
1088 !
1089 OUTPUT @Rec;"TRGSEXT;HOLD;" ! SET TO EXTERNAL TRIGGER FOR CONTROLLED
1090 !
1091 !
1092 Set_85330a:!
1093 !
1094 OUTPUT @hp85330a;"*RST;" ! SOFT RESET
1095 OUTPUT @hp85330a;"RUNT:EVEN:TRIG TTL;" ! Set the triggering.
1096 OUTPUT @hp85330a;"RUNT:EVEN:COUN ";Angle_pts;";" ! Angle increments
1097 !
1098 OUTPUT @hp85330a;"RUNT:TIME:EVEN 0,15000000;" ! timeout 1st point: 15 sec.
1099 OUTPUT @hp85330a;"RUNT:TIME:EVEN 1,5000000;" ! timeout 2nd - last: 5 sec.
1100 OUTPUT @hp85330a;"RUNT:TIME:REC 1000000;" ! timeout receiver: 1 sec.
1101 !
1102 OUTPUT @hp85330a;"RUNT:SWIT:DEL 50;" ! Switch settling is 50 uS.
1103 OUTPUT @hp85330a;"RUNT:SWIT:SCAN 1,(@";Switch_start;";";Switch_stop;");"
1104 !
1105 OUTPUT @hp85330a;"RUNT:SOUR:COUN ";Freq_pts;";" ! Frequency points.
1106 OUTPUT @hp85330a;"RUNT:SOUR:SOURCE1:TRIG IMM;" ! No External triggering.
1107 OUTPUT @hp85330a;"RUNT:SOUR:SOURCE2:TRIG IMM;" ! No External triggering.
1108 !
1109 !
1110 !
1111 Set_positioner:!
1112 !
1113 ! Set positioner to start angle.
1114 ! Set velocity, acceleration.

```

Programming
Programming Examples

```
1115 ! Set positioner to issue TTL triggers at increment angles.
1116 !
1117 !
1118 Start_meas:!
1119 !
1120 OUTPUT @Rec;"CLES;SING;" ! Start receiver single sweep.
1121 OUTPUT @hp85330a;"RUNT:INIT:IMM;" ! Start measurement process
1122 REM Set the positioner to take an angle scan. ! Start the positioner.
1123 !
1124 FOR Passes=1 TO Angle_pts
1125 REPEAT
1126 ! Wait for SING sweep to complete
1127 UNTIL BIT(SPOLL(@Rec),4)
1128 FOR N=1 TO Chan_pts
1129 OUTPUT @Rec;"PARA"&&VAL$(N)&";"
1130 OUTPUT @Rec;"FORM3;OUTPDATA;"
1131 ENTER @Rec_data;Preamble,Data_bytes
1132 ENTER @Rec_data;Data_freq(*)
1133 NEXT N
1134 IF Passes <> Angle_pts THEN
1135 OUTPUT @Rec;"CLES;SING;" ! Have the receiver take another sweep.
1136 END IF
1137 NEXT Passes
1138 !
1139 END
```

Programming Examples

Example 3

Example 3 applies to measurements where the HP 85330A controls the sources, using Fast Source Control mode.

```

1001  !
1002  ! RE-SAVE  "EXAMPLE_3.rmb"
1003  !
1004  Example_3: !
1005  !
1006  ! This example shows how to make multi-frequency, multi-channel
1007  ! measurements using the HP 85330A and the FAST DATA modes of the HP 8530A
1008  ! Microwave Receiver. In this mode the sources are setup by the computer
1009  ! rather than under control of the HP 8530A microwave receiver.
1010  !
1011  ! It uses the HP BASIC/WS TRANSFER command to read data from the receiver
1012  ! The HP BASIC command ENTER may also be used.
1013  !
1014  DIM Err_str$(128)
1015  INTEGER Data_f1(1:32000,0:2) BUFFER  ! DATA FROM RECEIVER IN FORMAT FORM1.
1016  !
1017  Build_table: !
1018  !
1019  ALLOCATE REAL Exp_tbl(0:255)
1020  !
1021  Build the FORM1 to FORM3 conversion table. During the FAST DATA
1022  ! acquisition from the HP 8530A data translation is need to conver the
1023  ! 6 bytes read from the receiver to a data point consiting of a
1024  ! real and imaginary pair.
1025  !
1026  Exp_tbl(0)=2^(-15)
1027  FOR N=0 TO 126
1028  Exp_tbl(N+1)=Exp_tbl(N)+Exp_tbl(N)
1029  NEXT N
1030  Exp_tbl(128)=2^(-143)
1031  FOR N=128 TO 254
1032  Exp_tbl(N+1)=Exp_tbl(N)+Exp_tbl(N)
1033  NEXT N
1034  !
1035  Set_vars: !
1036  !
1037  ! Set variables
1038  !
1039  Scu_addr=0           ! SCU address
1040  Chan_start=1        ! First Channel
1041  Chan_stop=4         ! Last Channel
1042  Chan_pts=(Chan_stop-Chan_start)+1 ! Number of channels
1043  Switch_start=Scu_addr*100+Chan_start ! Starting SWITCH ADDRESS
1044  Switch_stop=Scu_addr*100+Chan_stop  ! Ending SWITCH ADDRESS
1045  !
1046  Angle_start=-90
1047  Angle_stop=90
1048  Angle_incr=10
1049  Angle_pts=((Angle_stop-Angle_start)/Angle_incr)+1
1050  !
1051  Freq_start=3        ! GHz
1052  Freq_stop=5        ! GHz
1053  Freq_pts=11       ! Points
1054  Freq_offset=.020   ! Ghz
1055  Freq_step=(Freq_stop-Freq_start)/(Freq_pts-1)
1056  !

```

Programming

Programming Examples

```
1057 Points=Angle_pts*Chan_pts*Freq_pts ! Total points to be measured for
1058 ! ! a single angle scan
1059 !
1060 REDIM Data_f1(1:Points,0:2) ! 6 byte format.
1061 ALLOCATE REAL Data_f3(1:Points,1:2) ! Real and imaginary pairs
1062 !
1063 Rec_averages=1
1064 !
1065 ! Set HP-IB addresses
1066 !
1067 ASSIGN @Rec TO 716 ! ASSIGN HP 8530A HP-IB.
1068 ASSIGN @Rec_data TO 716;FORMAT OFF ! ASSIGN HP 8530A DATA HP-IB.
1069 ASSIGN @Rf TO 719 ! ASSIGN HP 8360 RF SOURCE HP-IB.
1070 ASSIGN @Lo TO 718 ! ASSIGN HP 8360 LO SOURCE HP-IB.
1071 ASSIGN @hp85330a TO 70918 ! Assign HP 85330A HP-IB
1072 ASSIGN @Buffer TO BUFFER Data_f1(*)! ASSIGN INPUT BUFFER.
1073 !
1074 Set_receiver: !
1075 !
1076 OUTPUT @Rec;"ADDRSOUR 31;" ! Since the HP 8530A does NOT have control of the
1077 OUTPUT @Rec;"ADDRSOU2 31;" ! sources, set the source address on the
1078 ! ! HP 8530A to 31.
1079 !
1080 OUTPUT @Rec;"FREQ;" ! Set to frequency domain
1081 OUTPUT @Rec;"SINC;" ! Set to single channel
1082 OUTPUT @Rec;"SINP;" ! Set to single point
1083 OUTPUT @Rec;"PARA1;" ! select b1/a1 ratio
1084 !
1085 IF Rec_averages>1 THEN
1086 OUTPUT @Rec;"AVERON";Rec_averages;" ! Turn averaging on.
1087 ELSE
1088 OUTPUT @Rec;"AVEROFF;" ! Turn averaging off.
1089 END IF
1090 !
1091 Set_8360:!
1092 !
1093 ! Place the source in SCPI language
1094 !
1095 OUTPUT @Rf;"SYST:LANG SCPI;"
1096 OUTPUT @Lo;"SYST:LANG SCPI;"
1097 !
1098 ! Place the source in STEP mode (or LIST mode).
1099 !
1100 OUTPUT @Rf;"FREQ:MODE SWE;"
1101 OUTPUT @Rf;"SWE:GEN STEP;"
1102 OUTPUT @Lo;"FREQ:MODE SWE;"
1103 OUTPUT @Lo;"SWE:GEN STEP;"
1104 !
1105 ! Set the Start, Stop, and number of points. Ths LO source must be offset
1106 ! by 20 MHz from the RF source.
1107 !
1108 OUTPUT @Rf;"FREQ:STAR ";Freq_start;" GHZ;"
1109 OUTPUT @Rf;"FREQ:STOP ";Freq_stop;" GHZ;"
1110 OUTPUT @Rf;"SWE:POIN ";Freq_pts;" ;"
1111 OUTPUT @Lo;"FREQ:STAR ";Freq_start+Freq_offset;" GHZ;" ! The LO source is
1112 OUTPUT @Lo;"FREQ:STOP ";Freq_stop+Freq_offset;" GHZ;" ! offset by 20 MHz.
1113 OUTPUT @Lo;"SWE:POIN ";Freq_pts;" ;"
1114 !
1115 ! The step sweep points triggering is external so that the HP 85330A can
1116 ! trigger the sources.
1117 !
1118 OUTPUT @Rf;"SWE:TRIG:SOUR EXT;"
```

Programming Examples

```

1119 OUTPUT @Lo;"SWE:TRIG:SOUR EXT;"
1120 !
1121 ! The start sweep trigger is AUTO.
1122 !
1123 OUTPUT @Rf;"TRIG:SOUR IMM;"
1124 OUTPUT @Lo;"TRIG:SOUR IMM;"
1125 !
1126 ! Set the power level and turn the power on.
1127 !
1128 OUTPUT @Rf;"POW:LEV -5;"
1129 OUTPUT @Lo;"POW:LEV 10;"
1130 OUTPUT @Rf;"POW:STAT ON;"
1131 OUTPUT @Lo;"POW:STAT ON;"
1132 !
1133 ! Don't initiate the sweep yet...
1134 !
1135 !
1136 Set_85330a:!
1137 !
1138 OUTPUT @Hp85330a;"*RST;" ! SOFT RESET
1139 !
1140 OUTPUT @Hp85330a;"RUNT:EVEN:TRIG TTL;" ! Set the triggering.
1141 OUTPUT @Hp85330a;"RUNT:EVEN:COUN ";Angle_pts;" ! No of angle increments
1142 !
1143 OUTPUT @Hp85330a;"RUNT:TIME:EVEN 0,15000000;" ! 15 sec, 1st point.
1144 OUTPUT @Hp85330a;"RU
1145 OUTPUT @Hp85330a;"RUNT:TIME:REC 1000000;" ! timeout receiver.
1146 !
1147 OUTPUT @Hp85330a;"RUNT:SWIT:DEL 2;" ! Switch settling is 2 uS.
1148 OUTPUT @Hp85330a;"RUNT:SWIT:SCAN 1,(@";Switch_start;"";Switch_stop;"");"
1149 !
1150 OUTPUT @Hp85330a;"RUNT:SOUR:COUN ";Freq_pts;" ! No of frequency points.
1151 OUTPUT @Hp85330a;"RUNT:SOUR:SOURCE1:TRIG TTL;" ! Set source to ext trig.
1152 OUTPUT @Hp85330a;"RUNT:SOUR:SOURCE2:TRIG TTL;" ! Set source to ext trig.
1153 !
1154 OUTPUT @Hp85330a;"SYST:ERR?;" ! Check error status
1155 ENTER @Hp85330a;Err_num,Err_str$ ! until error is 0.
1156 !
1157 Set_positioner:!
1158 !
1159 ! Set positioner to start angle.
1160 ! Set velocity, acceleration.
1161 ! Set start, stop and increment angles.
1162 !
1163 Start_meas:!
1164 !
1165 ! Set the HP 8530A in FAST AUTO-RANGING data mode.
1166 !
1167 OUTPUT @Rec;"FASAD;" ! SET THE RECEIVER TO FAST DATA w/ AUTO-RANGE.
1168 REPEAT ! WAIT UNTIL THE RECEIVER IS READY TO
1169 WAIT .001 ! TO TAKE DATA.
1170 UNTIL BIT(SPOLL(@Rec),2) !
1171 TRIGGER @Rec ! ISSUE HPIB TRIGGER TO BEGIN FAST DATA MODE.
1172 !
1173 ! Set the HP 85330A to intitiate the run time control.
1174 !
1175 OUTPUT @Rf;"INIT:CONT ON;" ! Initiate the rf
1176 OUTPUT @Lo;"INIT:CONT ON;" ! Initiate the lo source.
1177 OUTPUT @Hp85330a;"RUNT:INIT:IMM;" ! Initiate the HP 85330A run time mode.

```

Programming
Programming Examples

```
1178      !
1179      ! Set the positioner to take an angle scan.
1180      !
1181      REM Start the positioner.
1182      !
1183      ! This starts the data transfer from the receiver to the computer. When
1184      ! a trigger is issued to the receiver the data is placed into the receiver's
1185      ! buffer and then read from the receiver using the following TRANSFER
1186      ! statement.
1187      !
1188      TRANSFER @Rec TO @Buffer;RECORDS Points,EOR (COUNT 6)
1189      !
1190      N=1                      ! N IS THE CURRENT POINT.
1191      REPEAT
1192      !
1193      ! The TRANSFER statement is a background process that allows the
1194      ! computer BUFFER to be filled while the other commands are executed.
1195      ! Therefore, other code (i.e. drawing data to the display data can go
1196      ! here without hindering the measurement process.
1197      !
1198      ! The ENTER statement can also be used to read part or all of the trace
1199      ! instead of using the TRANSFER statement.
1200      !
1201      ! Remember that in FORM 1 data, which the HP 8530A uses in the FAST DATA
1202      ! modes each data point is 6 bytes. The 6 bytes must be converted to
1203      ! a real and imaginary pair.
1204      !
1205      ! --
1206      !
1207      STATUS @Buffer,4;R4      ! Check the number of bytes in the buffer
1208      IF R4>=6*N THEN         ! Is there another point (6 bytes) in the buffer?
1209      !
1210      ! If yes THEN convert the data from FORM 1.
1211      !
1212      Exp=Exp_tbl(BINAND(Data_f1(N,2),255))! CONVERT FORM1 TO FORM3.
1213      Data_f3(N,1)=Data_f1(N,1)*Exp      ! REAL DATA.
1214      Data_f3(N,2)=Data_f1(N,0)*Exp      ! IMAGINARY DATA.
1215      N=N+1
1216      END IF
1217      !
1218      UNTIL N>Points
1219      !
1220      CONTROL @Buffer,8;0      ! TERMINATE TRANSFER
1221      OUTPUT @Rec;"SINP;"      ! TAKE RECEIVER OUT OF FAST-CW MODE
1222      !
1223      END
```

HP 85330A Error Messages

Error Number	Error Message
+0	"No error"
-100	"Command error"
-101	"Invalid character"
-102	"Syntax error"
-103	"Invalid separator"
-104	"Data type error"
-105	"GET not allowed"
-108	"Parameter not allowed"
-109	"Missing parameter"
-112	"Program mnemonic too long"
-113	"Undefined header"
-121	"Invalid character in number"
-123	"Numeric overflow"
-124	"Too many digits"
-128	"Numeric data not allowed"
-131	"Invalid suffix"
-138	"Suffix not allowed"
-141	"Invalid character data"
-148	"Character data not allowed"
-150	"String data error"
-151	"Invalid string data"
-158	"String data not allowed"
-161	"Invalid block data"
-168	"Block data not allowed"
-170	"Expression error"
-171	"Invalid expression"
-178	"Expression data not allowed"
-181	"Invalid outside macro definition"

Error Number	Error Message
-183	"Invalid inside macro definition"
-200	"Execution error"
-210	"Trigger error"
-211	"Trigger ignored"
-213	"Init ignored"
-214	"Trigger deadlock"
-215	"Arm deadlock"
-221	"Settings conflict"
-222	"Data out of range"
-223	"Too much data"
-224	"Illegal parameter value"
-240	"Hardware error"
-241	"Hardware missing"
-270	"Macro error"
-272	"Macro execution error"
-273	"Illegal macro label"
-276	"Macro recursion error"
-277	"Macro redefinition not allowed"
-310	"System error"
-330	"Self-test failed"
-350	"Too many errors"
-400	"Query error"
-410	"Query INTERRUPTED"
-420	"Query UNTERMINATED"
-430	"Query DEADLOCKED"
440	"Query UNTERMINATED after indefinite response"
1000	"Out of memory"
1100	"Time/date memory lost"
1301	"Bad driver format"
1302	"Incorrect driver checksum"
1303	"LOAD command cannot understand driver format"
1304	"Instrument ROM revision not compatible with this driver"
1305	"Not enough driver RAM for this driver"

HP 85330A Error Messages

Error Number	Error Message
1306	"Not enough header entries for this driver"
1500	"Trigger source already allocated"
1501	"Instrument in use"
1510	"Trigger source non-existent"
2000	"Invalid card number"
2001	"Invalid channel number"
2002	"Invalid logical address"
2003	"Invalid word address"
2004	"Invalid address for 32-bit access"
2005	"No card at logical address"
2006	"Command not supported on this card"
2007	"Bus error"
2008	"Scan list not initialized"
2009	"Too many channels in channel list"
2010	"Scan mode not allowed on this card"
2011	"Empty channel list"
2012	"Invalid channel range"
2021	"Trigger line not supported by extender"
2145	"Config warning, Non-volatile RAM contents lost"
2601	"Channel list required for this function"

7

Remote Programming Command Reference

This chapter describes programming commands for the multiple channel controller.

Command Syntax

Common Command Format

Common commands are four or five characters in length, always begin with the asterisk character (*), and may include one or more parameters. The command keyword is separated from the first parameter by a space character. Some examples of common commands are:

```
*IDN? *CLS *OPC?
```

Standard Command Format

Standard commands perform functions such as making measurements, querying instrument states, or retrieving data. A command subsystem is a hierarchical structure that usually has a top level (or root) command, one or more low-level commands, and their parameters. This is an example of a typical subsystem:

```
RUNTime  
  :SOURce  
    :SOURCE1  
      :TRIGger
```

RUNTime is the root command, SOURce is a second level command, SOURCE1 is a third level command, and TRIGGER is a fourth level command.

A colon (:) always separates a command from the next lower level command, as shown below:

```
ROUTe:CLOSE
```

Abbreviated Commands

The command syntax shows most commands as a mixture of upper case (capital) and lower case letters. The upper case letters indicate the abbreviated spelling for the command. For shorter program lines, use the abbreviated form. For better program readability, you may use the entire command. The instrument will accept either the abbreviated form or the entire command.

For example, if the command syntax shows **TIMEout**, then both **TIME** and **TIMEOUT** are acceptable forms. Incorrect forms of **TIMEout**, such as **TIMEO** or **TIMET** will generate an error. You may use upper case or lower case letters. Therefore, **TIMEOUT**, **timeout**, and **TIMoUt** all are acceptable.

Parameters

The following table contains descriptions and examples of parameter types you might see later in this chapter.

Table 7-1 *Parameter Types*

Type:	Descriptions and Examples:
Numeric	Accepts all commonly used decimal representations of numbers including optional signs, decimal points, and scientific notation. 123, 123E2, -123, -1.23E2, 0.123, 1.23E-2, 1.23000E-01. Special cases may include MIN, MAX, and INF.
Boolean	Represents a single binary condition that is either true or false. ON, OFF, 1, 0
Discrete	Selects from a finite number of values. These parameters use mnemonics to represent each valid setting. An example is the TRIGger:SOURce:SOURCE1:TRIGger command, where TRIGger can be set to TTL or IMM .
Optional Parameters	Parameters shown within square brackets ([]) are optional parameters. (Note that the brackets are not part of the command and are not sent to the instrument.) If you do not specify a value for an optional parameter, the instrument chooses a default value. When specifying a parameter, be sure to place a space between the command and the parameter.

Common Commands

The following pages describe the common commands available in the HP 85330A multiple channel controller.

*CLS

***CLS**

Software clear of the HP 85330A. This clears the error stack.

Syntax

*CLS

Example

OUTPUT 70918; "*CLS"

***IDN?**

Returns the card manufacturer, model number, and firmware revision number.

Default

Should return the string: **HEWLETT-PACKARD,85330-60002,0,A.03.00**

Syntax

IDN?

Example

```
10 DIM IDN_STR$(128)
20 OUTPUT 70918;"*IDN?;"
30 ENTER 70918;IDN_STR$
```

***OPC?**

The operation complete command. This can be used to measure timing of a run-time sequence. The command ***OPC?** returns a value of 1 when evoked. Prior commands are executed before the completion of ***OPC?**.

Syntax

***OPC?**

Example

```
10 OUTPUT 70918;"RUNT:EVEN:COUN 1;"
20 OUTPUT 70918;"TRIG:SOUR IMM;"
30 TIME_START=TIMEDATE
40 OUTPUT 70918;"INIT:IMM;*OPC?"
50 ENTER 70918;OPC_NUM
60 TIME_STOP=TIMEDATE
70 PRINT "MEASUREMENT TIME (SEC)=";TIME_STOP-TIME_START
```

***RST**

A soft reset of the E1330A/B and 85330-60002 card. It is executed at power-up. This command does not clear the error stack.

Default

All card address are set to channel 1.

Syntax

*RST

Example

OUTPUT 70918;""*RST"

NOTE

A *RST will produce a trigger signal on the SRC 1 TRIG, SRC2 TRIG, and RCVR TRIG lines.

Standard Command Reference

The following pages describe HP 85330A multiple channel controller standard commands.

ROUTE

Subsystem Command Syntax

:CLOSe port,(@switch address [,switch address]);

:DELay <micro-seconds>;

:CONTrol <data>;

ROUTe:CLOSe

Closes individual switch states in direct control only. The parameters are the switch *port address*, 1 or 2 and the switch address. The switch address is the concatenation of the SCU address and the channel. Examples are provided earlier in this chapter.

This command can also be used to set the TTL level of the rear panel AUX 2 connector before entering run-time mode.

Default

All switch modules are set to channel 1. AUX 2 connector default is TTL LOW.

Syntax

```
ROUTe:CLOSe 1|2,(@ <switch address, or list of switch addresses>);
```

or

```
ROUTe:CLOSe 3,(@0|1);
```

Example

```
OUTPUT 70918;"ROUT:CLOS 1,(@102);"
```

Closes SCU address 1 channel 2.

```
OUTPUT 70918;"ROUT:CLOS 3,(@0);"
```

Sets AUX 2 to TTL LOW before run-time.

NOTE

Multiple switch address entries may be:

- Separated by commas if listing each switch address.
 - Separated by a colon for starting and ending switch addresses. Switch address lists may contain both comma and colon separators.
-

ROUTe:CONTrol

Controls the TTL state of the rear panel AUX 1 connector.

Default

Default is a TTL LOW.

Syntax

OUT:CONT <data>;

Example

ROUT:CONT 0;
Sets AUX 1 to TTL LOW

ROUT:CONT 1;
Sets AUX 1 to TTL HIGH

NOTE

The state of AUX 1 must be set before entering run-time mode.

ROUTe:DELaY

Adds a specific amount of delay between a switch address entry being asserted and the issuance of a measurement trigger. Delay is entered in micro-seconds.

Default

The default is 160 micro-seconds.

Syntax

ROUT:DEL <micro-seconds>;

Example

ROUT:DEL 200;

Set the trigger delay (settling time) to 200 micro-seconds.

NOTE

Most solid state switches are capable of changing states within a few micro-seconds.

RUNTime

Subsystem Command Syntax

RUNTime

:CONTroller CONTroller | REMote1 | REMote2;

:EVENT

:COUNT <number of primary increment angles>;

:TRIGger IMM | TTL;

:INITiate

:IMM;

:SWITCh

:DELay <microseconds>;

:SCAN port,(@switch address [,switch address]);

:TRIGger IMM | REMote1 | REMote2;

:SOURce

:COUNT <number of frequency points>;

:SOURCE1

:TRIGger IMM | TTL | REMote1 | REMote2;

:SOURCE2

:TRIGger IMM | TTL | REMote1 | REMote2;

:TIMEout

:EVENT 0 | 1, <microseconds>;

:RECeiver <microseconds>;

:REMote <microseconds>;

:SOURCE <microseconds>;

RUNTime:CONTroller

This command sets the multiple channel controller as the master CONTroller or the REMote1 or REMote2 controller. When the multiple channel controller is INITiated to the RUNTime mode, the controller will execute a sequence based on its CONTroller status.

Default

Default is CONTroller.

Syntax

```
RUNT:CONT CONT | REM1 | REM2;
```

Example

```
RUNT:CONT CONT;
```

NOTE

(This command is in revision A.02.31 or greater.) See “To Use Run-Time Control Mode” on page 6-12 for more information on the CONTroller, REMote1, and REMote2 executing sequence.

RUNTime:EVENT:COUNT

Set the number of increment angles to be measured during run-time control.

Default

Default is 1.

Syntax

RUNT:EVENT:COUN <number of angular increments>;

Example

RUNT:EVENT:COUN 91;

RUNT:EVENT:COUN 1;

NOTE

When performing a frequency response measurement at a single angle the increment would typically be set to 1. This is useful for taking a frequency response measurement at a single angle, determining the measurement time of frequency response measurement, or taking a “first” sweep for the HP 8360-series source.

RUNTime:EVENT:TRIGger

The event trigger source allows either TTL triggering to control the run-time sequencing or IMMEDIATE triggering to occur.

TTL Mode

In TTL mode, the run-time control will:

1. Wait for an event trigger.
2. When the event trigger occurs, run-time control asserts each switch address entry in the scan list (one at a time), issuing a measurement trigger to the receiver for each.
3. Repeats step 2 for each frequency (defined using RUNT:SOUR:COUN).

Typically TTL mode is used for angle scans of CW or multi-frequency responses.

IMM Mode

In IMM mode the HP 85330A issues the first trigger immediately on receiving the INIT:IMM command and continues on with the sequence. Typically, IMM mode is used for single angle frequency response measurements or timing measurements.

Default

The default is TTL.

Syntax

RUNT:EVENT:TRIGger TTL | IMM;

Example

OUTPUT 70918;"RUNT:EVEN:TRIG TTL;"

OUTPUT 70918;"RUNT:EVEN:TRIG IMM;"

RUNTime:INITiate:IMM

Initiates the run-time sequence and control of a measurement. All parameters must be set up prior to initiating **RUN:INIT:IMM**. Once the measurement is initiated it will run until completion or until a timeout has occurred. If a timeout does occur it will report the error to the error stack.

Default

The event trigger is defaulted to TTL. See other related commands for their defaults.

Syntax

```
RUNTime:INITiate:IMM;
```

Example

```
RUN:INIT:IMM;
```

RUNTime:SOURce:COUNT

Set the number of frequency points to be measured during the run-time sequence. For each frequency point, each entry in the scan list will be asserted and a trigger issued. If the SOURCE triggering method is IMM, no source TTL trigger signal is issued and the HP 8530A is assumed to control the sources. If the source triggering is TTL, a TTL signal is issued and the run-time sequence waits for the source ready line.

Default

The default is 1.

Syntax

RUNTime:SOURce:COUNT <number of frequency points>;

Example

```
RUNTime:SOURce:COUNT 1;  
RUNTime:SOURce:COUNT 51;
```

NOTE

For CW angle scan measurements the number of frequencies should be set to 1.

RUNTime:SOURce:SOURCE1:TRIGger

Selects IMM, TTL, REMote1, or REMote2 triggering for source 1 (the RF source).

Default

The default trigger mode is TTL.

Syntax

```
RUNTime:SOURce:SOURCE1:TRIGger IMM | TTL  
| REMote1 | REMote2;
```

Example

```
RUNT:SOUR:SOURCE1:TRIG IMM;
```

NOTE

In the fast source stepping mode (a.k.a. Turbo) the trigger is set to TTL. When using more than one multiple channel controller, the CONTroller controller would set the source trigger parameter to remote (REMote1 or REMote2), while the REMote1 or REMote2 controller sets its parameter to TTL.

RUNTime:SOURce:SOURCE2:TRIGger

Selects IMM or TTL triggering for source 2 (the LO source).

Default

The default trigger mode is TTL.

Syntax

```
RUNTime:SOURce:SOURCE2:TRIGger IMM | TTL  
| REMote1 | REMote2;
```

Example

```
RUNT:SOUR:SOURCE2:TRIG IMM;
```

NOTE

In the fast source stepping mode (a.k.a. Turbo) the trigger is set to TTL. When using more than one multiple channel controllers, the CONTROLLER controller would set the source trigger parameter to remote (REMote1 or REMote2), while the REMote1 or REMote2 controller sets its parameter to TTL.

RUNTime:SWITch:DELay

Used for the delay between asserting the switch address list entry of the RUNT:SWIT:SCAN command and the issuance of a receiver trigger. The input to the command is in microseconds.

Default

The default is 2 microseconds.

Syntax

RUNT:SWIT:DEL <microseconds>;

Example

```
RUNT:SWIT:DEL 50;  ! Set the trigger or setting
                   ! time to 50 micro-seconds.
```

NOTE

- When using the multiple-parameter display mode of the HP 8530A, the minimum switch settling time *setting* is 50 μ s. Using faster settling times can cause problems during the measurement.
- For the Fast Data Acquisition modes, 2 μ s settling time is recommended.

RUNTime:SWITCh:SCAN

Set up the list of channel addresses for run-time control. For each event increment signal received by the HP 85330A, each channel address entry will be asserted and a subsequent trigger issued to begin a measurement of each data point.

This command can also be used to set the TTL level of the rear panel AUX 2 connector during run-time mode.

Default

Scan list for port 1 and port 2 are empty.

AUX 2 connector default is TTL LOW.

Syntax

RUNT:SWIT:SCAN 1 | 2,(@ <switch address list>);

or

RUNT:SWIT:SCAN 3,(@0 | 1);

This command controls port AUX 2.0 sets the AUX 2 BNC to a TTL low. A1 sets AUX2 to a TTL high.

NOTE

AUX 1 *cannot* be controlled in RUNTime mode.

Example

RUNT:SWIT:SCAN 1,(@101,102,101,102);

RUNT:SWIT:SCAN 2,(@101,101,102,102);

RUNT:SWIT:SCAN 3,(@0);

Sets AUX 2 output to TTL LOW during run-time.

NOTE

Switch address list requirements are the same as the ROUT:CLOS command. A switch address scan list can remain empty and no data will be written to the port. If a port is not empty then an error will be issued if the scan lists for both ports do not contain the same number of entries.

RUNTime:SWITch:TRIGger

The switch trigger source allows either TTL triggering from the REMote controller to control the run-time sequencing or IMMEDIATE triggering to occur.

Default

The default trigger mode is IMM.

Syntax

RUNT:SWIT:TRIG IMM | TTL;

Example

RUNT:SWIT:TRIG TTL;

NOTE

This command is in revision A.02.31 or greater.

RUNTime:TIMEout:EVENT

A timeout setting for event triggers during run-time. The timeout for the event trigger input has separate timeouts:

- One prior to the first trigger being issued: RUNT:TIME:EVENT 0, *time in μ s*
- The other for all subsequent triggers: RUNT:TIME:EVENT 1, *time in μ s*

Default

The default for the first trigger is 15 seconds (15000000 microseconds) and for subsequent triggers is 10 seconds (10000000 microseconds).

Syntax

```
RUNT:TIME:EVENT 0|1, <microseconds>;
```

Example

Examples of each timeout:

```
OUTPUT 70918;"RUNT:TIME:EVENT 0,15000000;"  
Set first EVENT TRIG timeout to 15 seconds.
```

```
OUTPUT 70918;"RUNT:TIME:EVENT 1,2000000;"  
Set the timeout for subsequent triggers to 2 seconds
```

```
OUTPUT 70918;"RUNT:TIME:REC 1000000;"  
Set RCVR READY timeout to 1 sec
```

```
OUTPUT 70918;"RUNT:TIME:SOURCE1 1000000;"  
Set source 1 timeout to 1 sec
```

```
OUTPUT 70918;"RUNT:TIME:SOURCE2 1000000;"  
Set source 2 timeout to 1 sec
```

RUNTime:TIMEout:RECeiver

Allows a timeout to occur if the receiver ready line does not respond in determined time.

Default

The default is 1 second (1000000 microseconds)

Syntax

RUNT:TIME:REC <microseconds>;

Example

RUNT:TIME:REC 1000000;

RUNTime:TIMEout:REMOte

Allows a timeout to occur if the REMote1 or REMote2 controller does not respond in determined time.

Default

The default is 1 second (1000000 microseconds)

Syntax

RUNT:TIME:REM <microseconds>;

Example

RUNT:TIME:REM 1000000;

NOTE

This command is in revision A.02.31 or greater.

RUNTime:TIMEout:SOURce

Allows a timeout to occur if the source 1 or source 2 ready line does not respond in determined time.

Default

The default is 1 second (1000000 microseconds)

Syntax

RUNT:TIME:SOUR <microseconds>;

Example

RUNT:TIME:SOUR 1000000;

SYSTem

Subsystem Command Syntax

SYSTem
:ERRor?

SYSTem:ERRor?

Allows checking the error status of the HP 85330A.

Default

The default should be: +0, "No error".

Syntax

SYST:ERR?

Example

```
10 DIM ERR_STR$(128)
20 OUTPUT 70918;"SYST:ERR?;"
30 ENTER 70918;ERR_STR$
```

NOTE

The errors are put into a stack, therefore reading the error status once may not clear all error conditions. It should be read until the error +0, "No error" is read. The *CLS command will clear the error status.

Remote Programming Command Reference
SYSTem:ERRor?

8

In Case of Difficulty

The HP 85330A Does Not Show the Main Menu When Turned ON

The following screen should appear when you turn the HP 85330A ON.

Select an instrument._

SYSTEM 85330A IBASIC (see note below)

NOTE

IBASIC is present if the IBASIC option is installed.

If you do *not* see this display, load the HP 85330A downloadable driver files as explained in Chapter 1, “Installation”.

9

Service

Introduction

This chapter explains the following topics:

- Theory of Operation (how the multiple channel switching system works.)
- Recommended Test Equipment (the equipment required for servicing these instruments.)
- Service
 - Troubleshooting (how to determine which part of the system is faulty.)
 - Replaceable Parts (how to identify and order parts.)
 - Assembly/Disassembly (how to remove and replace failed assemblies.)
 - Adjustments (how to make any adjustments or settings required.)
 - Preventive Maintenance (what service should be done as a preventive.)

CAUTION

The assemblies used in the multiple channel controller system are static sensitive. Use anti-static techniques when performing the following procedures. For example, wear an anti-static ground strap and work at a station equipped with an anti-static mat.

Theory of Operation

The HP 85330A multiple channel controller was designed as a high-speed, real-time controller for the HP 8530A microwave receiver. The HP 85330A controls external solid-state transmit and receive switches and allows for asynchronous TTL communications to the receiver, the RF and LO sources, and other remote HP 85330As. It is implemented using a standard VXI mainframe and has a downloadable software driver that provides the controllers with their own HP-IB command set for control, set-up and initiating runtime sequences.

A diagram of the entire system is shown in the HP 85330A System Block Diagram. All of the connections from the HP 85330-60002 card's rear panel to other instruments are optional. And may be different for each system, depending on the system's requirements from the HP 85330A.

NOTE

A receiver may use the STOP SWEEP line, if the RCVR READY line is not available.

The HP 85330A was implemented using an HP 75000 Series B VXI mainframe. A special VXI card was developed to handle the necessary control and timing requirements. This card is driven by a standard VXI parallel interface card (Digital I/O card.) A downloadable software driver was developed to provide fast runtime control of the measurement system.

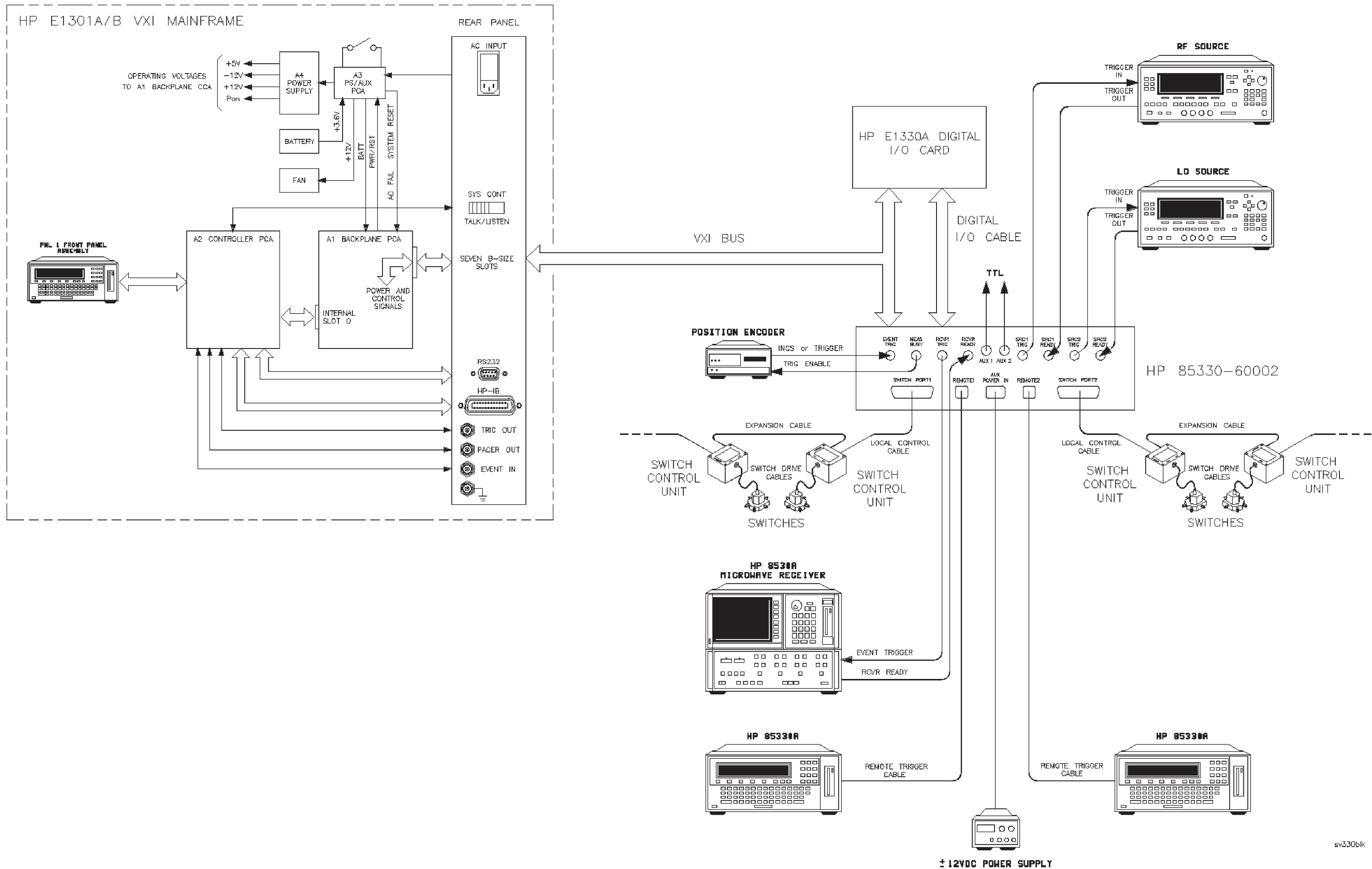

Figure 9-1. HP 85330A System Block Diagram

The HP 85330-60002 card contains the TTL trigger and ready lines that interface to the HP 8530A microwave receiver, the RF source, and the LO source. The communication to the switch control unit is through sets of parallel twisted-pair wires and bias wires. These wires enable placement of the switches next to the transmit and receive devices. This minimizes the RF path lengths to the external mixer modules and therefore decreases the amount of RF losses.

Configuration of the HP 85330A is achieved by sending a series of HP-IB commands to the mainframe prior to the runtime. To initiate the runtime sequence, an HP-IB command is issued to the controller, or the controller begins the measurement sequence or, waits for a trigger signal to the EVENT TRIG to begin the sequence. For the latter, the controller repeats the sequence for each trigger sent to the EVENT TRIG.

Figure 9-2 on page 9-6 shows the timing sequence of a typical measurement using the HP 85330A. Table 9-1 on page 9-6 shows the time required for each trigger shown in Figure 9-2 on page 9-6. This measurement not only controls a transmit and receive switch, but may optionally control the RF and LO sources for high speed frequency switching during the measurement. Upon receiving a trigger from the Positioner Controller or other trigger source, the HP 85330A issues the receiver trigger, waits for the receiver ready line, asserts the next set of switch states, waits for the switches to settle, and issues the receiver another trigger. To change frequency, the HP 85330A triggers the RF and LO sources and waits for the source ready lines before proceeding to the next set of switch states.

Service
Theory of Operation

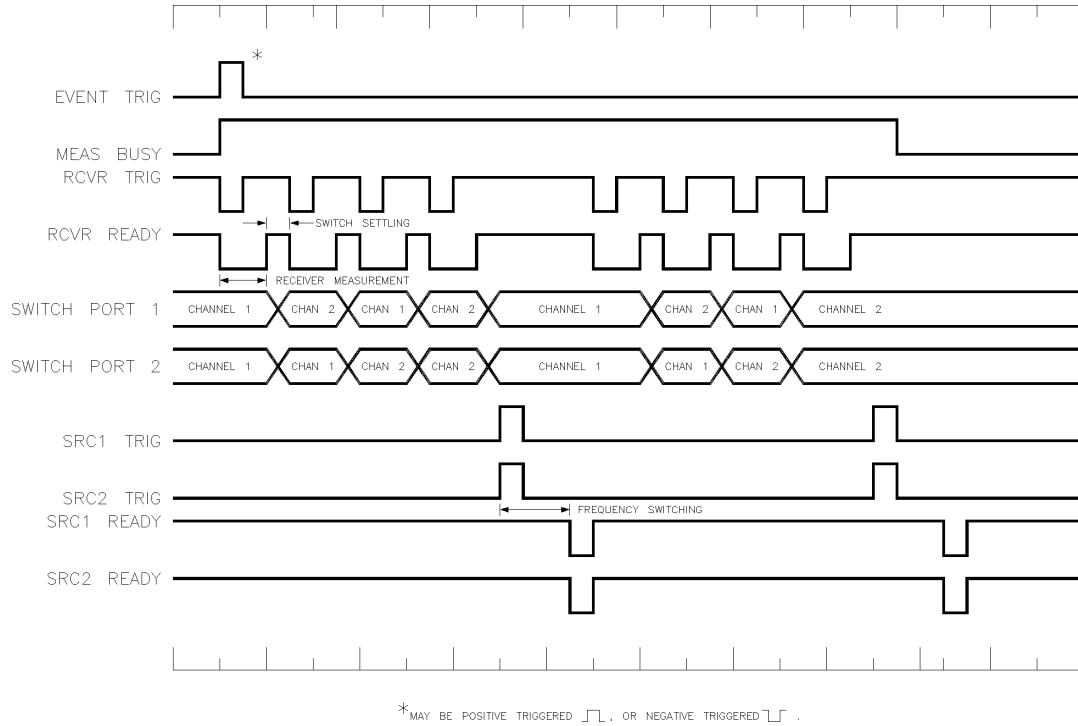

* MAY BE POSITIVE TRIGGERED OR NEGATIVE TRIGGERED .

Figure 9-2 HP 85330A Timing Sequence of a Typical Measurement

Table 9-1 Timing Sequence Trigger Widths

Trigger	Width	Description
EVENT TRIGGER	$1 \mu\text{s} \leq t_{ev} \leq 1 \text{ ms}$	Trigger width dependent on trigger source
MEAS BUSY		Dependent on measurement time of HP 85330A
RCVR TRIG	$1 \mu\text{s} \leq t_{rc} \leq 3 \mu\text{s}$	
RCVR READY:		
Switch Settling	Default 2 μs	Set by HP 85330 command- RUNT:SWIT:DEL
Receiver Measurement	typ. $\geq 200 \mu\text{s}$	Dependent on measurement time of HP 85330A
SWITCH PORT 1	Variable	Dependent on RCVR TRIG and RCVR READY lines
SWITCH PORT 2	Variable	Dependent on RCVR TRIG and RCVR READY lines
SRC 1 TRIG	$10 \mu\text{s} \leq t_{sr1} \leq 14 \mu\text{s}$	
SRC 2 TRIG	$10 \mu\text{s} \leq t_{sr2} \leq 14 \mu\text{s}$	
Frequency switching	typ $\geq 5 \text{ ns}$	Dependent on frequency switching time of source
SRC 1 READY	typ 1 μs	Trigger width dependent on trigger source
SRC 2 READY	typ 1 μs	Trigger width dependent on trigger source

For large systems, the distance between the transmitters and receiver may exceed the physical capabilities of a single controller. For these applications multiple controllers can be used. The REMOTE1 and REMOTE2 provide the communications between controllers via two balanced twisted-pair wires, similar to RS-422. In defining the runtime parameters, the event sequence is also defined which enables the controllers to operate in unison via these wires.

The AUX POWER IN allows for use of an external ± 12 Vdc power supply to be used if the VXI mainframe can not supply the required power for a large switching system, or to compensate for local control cable losses, or special switch voltages. The AUX 1 and AUX 2 outputs can provide a user-controllable TTL line for special applications.

The HP 85330-60002 card communicates with the switch control units via the SWITCH PORT1 and SWITCH PORT2 connectors. These SCUs decode the switching control signals and provide bias for the Switches. The physical connection of a switch control module is accomplished using one of the two independent output ports on the HP 85330-60002 card. The separate ports provide the cabling requirements for remote switches to the transmit and receive sites. The cascading feature provides for building switch trees, or simultaneous switching into multiple RF channels.

Switch control units can be individually addressed for independent control, or can share the same address for simultaneous switching or tree configurations. Each module has two bits of unit-address decode and six bits of channel-address decode. The six channel-address bits allow unique addressing for switches up to a 64 throw switch.

For the detailed theory of operation for the HP E1301B VXI mainframe, see the Service chapter in the *HP E1301B Service Manual*.

Recommended Test Equipment

Table 9-2 lists the equipment that is mandatory when servicing the multiple channel controller and switches. Other equipment can be substituted if it meets or exceeds the requirements for the tests, or the requirements specified below.

Table 9-2 Required Test Equipment

Qty	Item	HP Part or Model Number	Use ¹
1	Downloadable Driver Disk	85330-10016 ²	I, T, P
1	Multimeter ± 20 Vdc, digital	E2377A	P, T
1	Digital Oscilloscope (1 MHz Single-shot Band Width)	HP 54501A	P, T
1	Tee Adapter (BNC male to female, female)	1250-0781	P, T
3	Cable (BNC male to male 122 cm)	8120-1840	P, T
1	Network Analyzer System ³ 50 MHz to 40 GHz ^{4,5} 90 dB dynamic range	HP 8722C option 003	P, T
1	Plotter or Printer ⁶	HP 7550A+ or LaserJet	P
1	Torque Wrench 2.4/3.5 mm (8 in-lb)	8710-1765 ⁷	P, T, I, O
1	TORX Driver T-8	8710-1673	T
1	TORX Driver T-10	8710-1284	T
1	TORX Driver T-15	8710-1816	T
1	Posidriv No.1	8710-0899	T
1	Posidriv No.2	8710-0900	T
1	Soldering Iron		T

1. O = Operation
P = Performance Verification
A = Adjustments
T = Troubleshooting
I = Installation

2. Included with the HP 85330A shipment.

3. System must include vector network analyzer, test port cables and calibration kit.

4. A 50 MHz to 26.5 GHz network analyzer may be used if the 3.5 mm adapters are used with the microwave switches.

5. If a network analyzer is used with a frequency range less than the switches, then the performance verification will only be valid over the frequency range of the network analyzer.

6. Plotter or printer must connect to the network analyzer and oscilloscope for test documentation.

7. Use this wrench for any 2.4/3.5/SMA mm connections in the procedure.

Service

CAUTION

The assemblies used in the multiple channel controller system are static sensitive. Use anti-static techniques when performing the following procedures. For example, wear an anti-static ground strap and work at a station equipped with an anti-static mat.

CAUTION

Do not disconnect or remove any boards from the mainframe unless the mainframe is unplugged. Some boards contain devices that can be damaged if the board is removed when the power is on. Several components, including MOS devices, can be damaged by electrostatic discharge. Use a proper ESD workstation when servicing this instrument.

NOTE

It is assumed that the person performing the service tests understands how to operate the multiple channel controller and the specified test equipment. Equipment settings, other than those used for the multiple channel controller, are stated in general terms. For example, a test might require that a voltage of +5 Vdc be measured, however the Digital Multimeter instructions as to mode and range would not be specified and the operator would be expected to set that control and any other controls as required to obtain a measurement. It is also assumed that the technician will select the cables, adapters, and probes required to complete the test setups illustrated in this section.

Troubleshooting

Troubleshooting the System

An understanding of how the HP 85330A system operates is required before undertaking the troubleshooting of this system. Please read “Theory of Operation” on page 9-2.

This system may be broken down into four parts; multiple channel controller (mainframe), switch control unit, RF switch, and cables. In order to determine which part of the system is not working correctly a performance verification may be run. For more information, see Chapter 2, “Performance Verification”.

Troubleshooting the Multiple Channel Controller

Turn ON Self Check

The following screen should appear when you turn the HP 85330A ON.

Select an instrument._

SYSTEM 85330A IBASIC (see note below)

NOTE

IBASIC is present only if the IBASIC option is intalled.

If you see this display, go on to the next troubleshooting section. If you *do not* see this display, load the HP 85330A downloadable driver files as explained in Chapter 1, “Installation”.

Multiple Channel Controller

Run “Verifying the Multiple Channel Controller” tests in Chapter 2, “Performance Verification”.

VXI Mainframe

For troubleshooting information on the HP E1301B VXI mainframe, see the Service chapter in the *HP E1301B Service Manual*. There are a couple of VXI mainframe self tests that can be used, as well as the command *TST?.

85330-60002 Card

The Multiple Channel Controller tests, shown above, will check this plug-in card.

To check the SWITCH PORT1 and SWITCH PORT2 output connector, refer to Table 9-3 on page 9-11 for each control line function. Use a digital scope or a logic analyzer to monitor these lines.

Table 9-3 SWITCH PORT 1/2 Connector Pinout

D-Type Connector Pins	Function	D-Type Connector Pins	Function
1	Bit 6 HI	14	Bit 2 HI
2	Bit 6 LO	15	Bit 2 LO
3	Bit 7 HI	16	Bit 3 HI
4	Bit 7 LO	17	Bit 3 LO
5	+ 12 Vdc	18	Bit 4 HI
6	+ 12 Vdc	19	Bit 4 LO
7	GND	20	Bit 5 HI
8	GND	21	Bit 5 LO
9	GND	22	+ 12 Vdc
0	Bit 0 HI	23	– 12 Vdc
11	Bit 0 LO	24	GND
12	Bit 1 HI	25	GND
13	Bit 1 LO		

Troubleshooting the Switch Control Unit

Run “Verifying the Switch Control Unit” tests in Chapter 2, “Performance Verification”.

NOTE

Check to make sure that the serial number prefixes of the Switch Control Unit and RF switch match. They are produced at the factory this way. It is acceptable to use switches and SCUs with different serial numbers. But if there is a problem it may be because a newer switch is used with a older SCU (or vice versa.)

Troubleshooting the RF Switch

Run “Verifying the RF Switches” tests in Chapter 2, “Performance Verification”.

Troubleshooting the Cables

The cables will be checked during “Verifying the Switch Control Unit” and “Verifying the RF Switches” tests in Chapter 2, “Performance Verification”.

If a cable is suspected, use a voltmeter to check continuity between the connectors on each end of the cable. See Table 9-4 on page 9-12 for the wiring information for each set of cables.

HP 85383A Local Control Cable

Use Table 9-4 to check each connector pin for continuity.

Table 9-4 *HP 85383A Connector Wiring Table*

D-Type Connector Pins	Circular Connector Pins	D-Type Connector Pins	Circular Connector Pins
1	A	14	K
2	C	15	R
3	B	16	S
4	D	17	X
5	E	18	T
6	L	19	Y
7	nc ¹	20	U
8	F	21	Z
9	M	22	V
10	H	23	a
11	N	24	W
12	J	25	b
13	P		

1. nc = No Connection

HP 85383B Expansion Cable

This cable has the same connector type on each end; one end male, and the other female. Each pin on one connector will have continuity with the same pin on the other end. Remember that each pin on one connector will be on the opposite side of the connector face on the other connector (i.e. they are mirror images of each other.)

HP 85384A Switch Driver Cable

This cable has the same connector on each end, and each pin on one connector will have continuity with the same pin on the other end.

HP 85385A Remote Trigger Cable

This cable has the same connector on each end, but is wired to cross-connect the inputs and outputs from the multiple channel controller. See Table 9-5 on page 9-13 for more information.

Table 9-5 *HP 85385A Wiring*

Connector 1	Connector 2	Function
1	1	nc ¹
2	2	nc ¹
3	3	shield
4	4	nc ¹
5	5	nc ¹
6	8	tx/rx
7	9	tx/rx
8	6	rx/tx
9	7	rx/tx

1. nc = No Connection

Replaceable Parts

This section contains information for ordering replaceable parts for the multiple channel switch system. The replaceable parts include major assemblies and chassis hardware.

Parts List Description

The following tables show the location and identification of replaceable parts. The list provides the following information:

1. Reference designator: identifies the part in the accompanying figure.
2. Hewlett-Packard part number.
3. Part quantity as shown in the corresponding figure. (There may or may not be more of the same part elsewhere in the instrument.)
4. Part description, and identifying or functional name.

Ordering Information

To order a part, quote the Hewlett-Packard part number, indicate the quantity required, and address the order to the nearest Hewlett-Packard office.

To order a part that is not listed in the replaceable parts lists, include the instrument model number, complete serial number, the description and function of the part, and the number of parts required. Address the order to the nearest Hewlett-Packard office.

How to Order Parts Fast!

The fast ordering system only applies in the United States. Outside the United States, contact your nearest HP office.

When you know which parts you need, contact Hewlett-Packard's direct ordering team by calling this toll-free number:

800-227-8164 (Monday through Friday, 6 am to 5 pm PST)

The parts specialists have direct access to the replacement parts listed in this manual. There is a charge for hotline one day delivery, but four day delivery is standard. After hours and holidays, call 415-968-2347.

Replaceable Parts

The multiple channel switch controller system consists of the following modules: mainframe and plug-in cards, switch control unit, RF switch, and interconnect cables. For information on replaceable parts for each module, see each of the following sections:

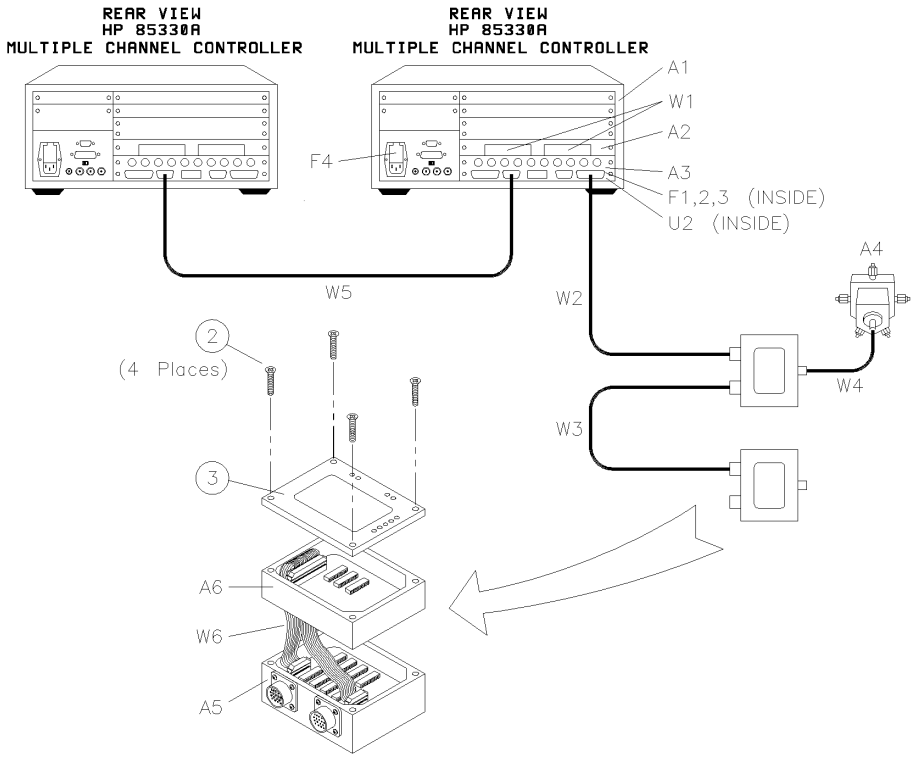

Figure 9-3 HP 85330A System Identification Diagram

**Mainframe, Plug-in
Cards**

The mainframe consists of a HP E1301B VXI mainframe. For information of replaceable parts for this mainframe, see Replaceable Parts chapter of the *HP E1301B Service Manual*.

Table 9-6 HP 85330A Mainframe Replacement Parts

Reference Designator	Description	Part Number	Qty.
A1	VXI Mainframe	HP E1301B (option 010)	1
A2	Digital I/O Card for VXI Size B	HP E1330B	1
A3	HP 85330-60002 Card	85330-60002	1
U2	A3U2 PAL for HP 85330A standard	85330-80013	1
	A3U2 PAL for HP 85330A H30	85330-80014	1
W1	A2-A3 Ribbon Cable Assembly 0.45 m	85330-60013	2
F1	Fuse 1A 125V for +5 Vdc int. bias	2110-0047	1
F2	Fuse 4A 125V for +12 Vdc ext. bias	2110-0476	1
F3	Fuse 1A 125V for -12 Vdc ext. bias	2110-0047	1
F4	Fuse 3A 250V for 115 Vac operation	2110-0043	
	Downloadable Driver Disk, rev A.03.00	85330-10016	
	Rack mount kit <i>without</i> handles (option 908)	5062-3978	
	Rack mount kit <i>with</i> handles (option 913)	5962-3984	
	<i>HP 85330A Operating and Service Manual</i>	85330-90019	
	<i>E1301B Users Manual</i>	E1300-90005	
	<i>E1301B Installing Drivers Note</i>	E1300-9021	
	<i>E1301B Service Manual</i>	E1300-90015	
	<i>E1330A/B Users Manual</i>	E1330-90004	
	<i>E1330A/B Service Manual</i>	E1330-90012	

Switch Control Unit

Table 9-7 HP 85331/2 Switch Control Unit Replacement Parts

Reference Designator	Description	Part Number	Qty
A5	Address Decoder Module	85331-60051	1
A6	Switch Driver Module	85331-60052	1, 2, 3
W6	A5-A6 Ribbon Cable Assembly: if one A6 module - If two or three A6 modules -	85331-60016 85331-60027	1
2	Screw M4 FH #2 Phillips: one driver module M45 - two driver modules M80 - three driver modules M110 -	0515-2424 0515-2425 0515-2423	4
3	Lid	85331-20011	1
	Lid Label: Standard - Special - Special -	85331-80018 85331- 80019 85331-80020	1
	Light Pipe	85331-20005	9
	Light Pipe Shrink Tubing	0890-0029	1
	Gasket Seal	0905-1154	1 per module

RF Switch

Table 9-8 HP 85331/2 Switch Replacement Parts

Reference Designator	Description	Part Number	Qty
A4	HP 85331A 2P Switch 0.045 to 40 GHz (NEW) (EXCHANGE)	85331-60031 85331-69031	1
A4	HP 85332A 4P Switch 0.045 to 40 GHz (NEW) (EXCHANGE)	85332-60001 85332-69001	1

Interconnect Cables

Table 9-9 *HP Replacement Interconnect Cables for HP 85330/31/32*

Reference Designator	Description	Part Number
W2	HP 85383A Local Control Cable:	
	Option 002, 2 meters length -	85330-60020
	Option 005, 5 meters length -	85330-60018
	Option 010, 10 meters length -	85330-60019
	Option 020, 20 meters length -	85330-60011
	Option 030, 30 meters length -	85330-60023
	Option 040, 40 meters length -	85330-60024
Option 050, 50 meters length -	85330-60021	
W3	HP 85383B Expansion Control Cable:	
	0.5 meters length -	85331-60011
W4	HP 85384A Switch Driver Cable:	
	Option 001, 1 meters length -	85331-60025
	Option 002, 2 meters length -	85331-60026
	Option 005, 5 meters length -	85331-60021
	Option 010, 10 meters length -	85331-60022
W5	HP 85385A Remote Trigger Cable ¹	

1. There is no replacement cable available. Cable must be repaired, instead of replaced.

Assembly and Disassembly

CAUTION

The assemblies used in the multiple channel controller system are static sensitive. Use anti-static techniques when performing the following procedures. For example, wear an anti-static ground strap and work at a station equipped with an anti-static mat.

Mainframe

For assembly and disassembly information on the HP E1301B VXI mainframe, see the Service chapter in the *HP E1301B Service Manual*.

Disassembly

1. Turn OFF the ac power switch and remove ac power cable.
2. Loosen the six screws on the E1330 and 85330-60002 card assemblies.
3. Gently slide out both cards together.
4. Remove the ribbon cables from each board by pushing the locking tabs out of the way on each connector and lifting the ribbon connector out of the board connector.

Assembly

1. Make sure that the ac power switch is turned OFF and remove the ac power cable.
2. Ensure that the E1330B card is properly configured. Refer to “E1330 Card Configuration” on page 9-20 for more information.
3. Ensure that the 85330-60002 card is properly configured. Refer to “E1330 Card Configuration” on page 9-20 for more information.
4. Fold the two ribbon cables like a fan.
5. Connect a ribbon cable to each panel connector on the E1330 with the ribbon cable pointed down.
6. Place the E1330 card on top of the 85330-60002 card.
7. Connect the other end of each ribbon cable to the circuit board connector P2 and P3 on the 85330-60002 card.

NOTE

The cables should not be twisted or cross each other. They should lay flat between the two cards. Make sure that all four connectors are properly seated.

- Place the E1330 card on top of the 85330-60002 card and slide them into the mainframe.
- Tighten all six screws.

E1330 Card Configuration

Before installing a new E1330 card, make sure that it is configured correctly for the system that it will be installed in.

- The LADDR (logical address) or SW1 should be set to:

Bit	7	6	5	4	3	2	1	0
Set	1	0	0	1	0	0	0	0

This sets the secondary HP-IB address to 144. (The secondary address is the logical address divided by 8, which is 18.)

- IRQ jumpers JM15 and JM16 are both set to position 1.
- PULL UP MODE jumpers J51, J52, J53, and J54 are ENABLED.
- FLG COMBINE jumpers should be empty, NO JUMPERS NEEDED.

85330-60002 Card Configuration

Before installing a new 85330-60002 card, make sure that it is configured correctly for the system that it will be installed in.

- Note that sockets J8, J9, and J10 are not normally used.
- Insure that the correct fuses are installed in F1, F2, and F3. Refer to Table 9-6 on page 9-16 for a list of these fuses.
- Insure that the correct U2 PAL is installed. Refer to Table 9-6 on page 9-16 for the correct part number.
- Make sure that the card is set correctly for the system's trigger (either positive or negative edged triggering.)

NOTE

Most positioner controllers put out a positive edged trigger, but most other trigger sources use a negative edged trigger. The default triggering is positive edged. To configure the triggering, refer to "Selecting Positive or Negative-Edge Event Triggers on the HP 85330-60002 Card".

- Make sure that the correct jumpers are set for internal or external dc bias. This sets the source of the RF switch dc bias (internal for a small number of switches, or external for a large number of switches.) The default is internally powered. To configure the power, see "Switching From the Internal to External Power Supply" on page 9-25.

Switch Control Unit

Disassembly

1. Remove the Local Control cable and Switch Drive cable.
2. Remove the four screws from the lid of the Switch Control Unit.
3. Pull the unit apart.

CAUTION

Be careful not to damage the gasket seal in each module.

4. Remove the ribbon cable from the Drive module and the Decoder module.
5. Do not change any switch settings in any of the modules!

Assembly

1. If you are installing a new Decoder or Driver module, the switches S1 and S2 must be set correctly. If you are replacing a module, set the switches for the same setting as the old module. If you are unsure, here is the factory default settings:
 - The *Decoder module* switches are normally factory set to “all closed” for S1 and S2.
 - The *Driver module* switches are normally factory set to “all closed” for S1 and S2.
2. Check PAL U2 and U3 in sockets XU2 and XU3 on the Driver module. The module should contain both PALs, unless there is more than one driver module. If the SCU has more than one driver module, then only the first (bottom) should have both XU2 and XU3 filled with a PAL. Any modules after the first should only have PAL U2 installed. Remove PAL U3 from socket XU3 for these modules.
3. Make sure that the gasket seal is properly installed in each module housing.
4. Install the A5-A6 ribbon cable as follows:
 - a. Plug the 16 pin connector into the decoder board socket J3.
 - b. Plug the 14 pin connector into the decoder board socket J4.
 - c. Insert the free end of the cable with the 30 pin connector through the large notch in the driver board from the bottom.
 - d. Lower the Driver module onto the Decoder module, pulling the ribbon cable through the opening.
 - e. Plug the 30 pin connector into the driver board socket J1.
 - f. Pull the excess length of the ribbon cable up from the Decoder module into the Driver module. Fold the excess length of the cable over the top of the driver board.

Assembly and Disassembly

5. Place the lid (including the light pipes) onto the Driver module housing.
6. Screw the lid onto the housing. Tighten to about 7 in-lbs to insure that the SCU is environmentally sealed.

Adjustments

There are no adjustments that can be made in the mainframe, Digital I/O card, or the RF switch. Any other adjustments, or settings, that may be performed due to a part replacement or service, is shown below.

Selecting Positive or Negative-Edge Event Triggers

HP 85330-60002 Card

By default, the positive-edge of the EVENT TRIG line starts the measurement on the HP 85330-60002 card. If this card is replaced, the EVENT TRIG line may be required to be changed to a negative-edge trigger. To change this, perform the following procedure.

CAUTION

This device contains devices that are sensitive to static discharge. When you remove the cover of this device, observe static safety precautions:

- Place the unit on a grounded anti-static mat.
- Wear a grounded wrist strap, or
- Foot straps are only acceptable if you wear one on each foot, and if you are standing on a grounded floor mat.

See Figure 9-4 on page 9-24.

Service Adjustments

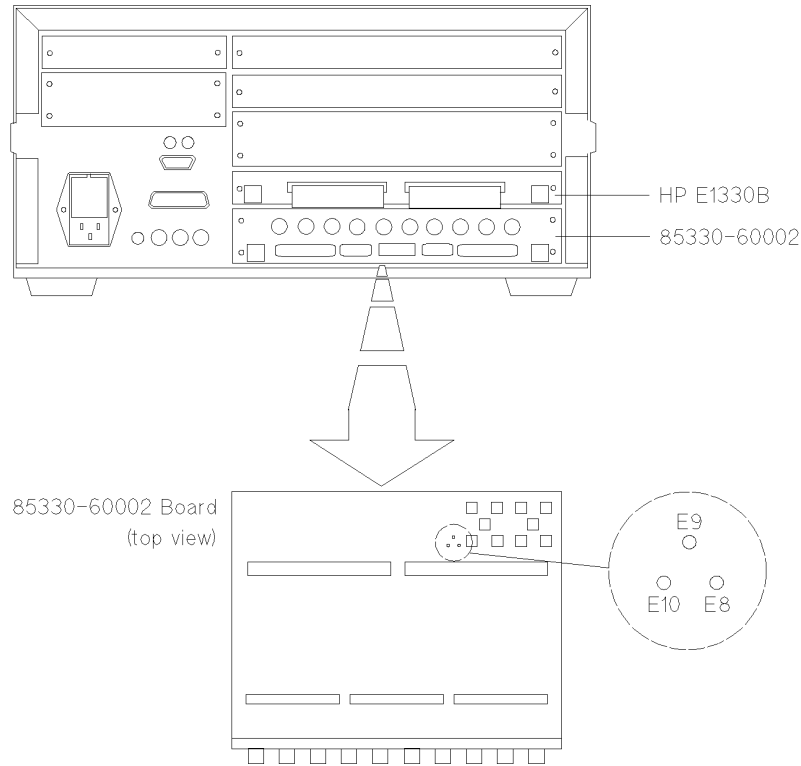

Figure 9-4 *Positive/Negative-Edge EVENT TRIG jumpers*

1. Remove the two screws that hold the HP E1330B board in place.
2. Remove the four screws that hold the 85330-60002 board in place.
3. Pull out the two boards at the same time. You can do this by pulling each one out a little at a time, until they are both removed. *Place the boards on an anti-static surface.*

Standard positive-edge operation is set at the factory by jumpering E9 and E10 together.

4. To select negative-edge operation, move the jumper across E9 and E8.
5. Reinstall the boards and screws.

Selecting the Multiple Channel Controller's HP-IB Address

The factory default setting of the HP-IB address is 9. To view the HP-IB address:

Press [Select Instr] {SYSTEM} {HP-IB} {READ}

To change the current HP-IB address:

1. Press [Select Instr] {SYSTEM} {HP-IB} {SET}
2. Enter the new address and press [Return].

Switching From the Internal to External Power Supply

This set of jumpers sets the 85330-60002 card to use in the internal VXI power supply to bias the remote RF switches and Switch Control Units, or to use the AUX POWER IN connector to bias the switches and SCUs. The internal power supply is used when there is few SCUs and RF switches. The AUX POWER IN is used when there are a large number of switches and SCUs, or if the switches require a special dc voltage, or to compensate for losses in a long Local Control Cable. The default is the internal power supply.

To set these jumpers, perform the following on the 85330-60002 card. This card must be removed before changing this switch. Refer to “Assembly and Disassembly” on page 9-19 for information on removing the card.

1. Locate the jumpers W1 and W2 near the rear panel of the 85330-60002. They will be next to the AUX POWER IN connector.
2. To set the card to the internal supply, the W1 jumper should go from +12V to INT, and the W2 jumper should go from –12V to INT.
3. To set the card to the AUX POWER IN supply, the W1 jumper should go from +12V to AUX, and the W2 jumper should go from –12V to AUX.

Table 9-10 *AUX Power In Connector Pinouts*

– 12 V	+ 12 V	+ 12 V	+ 12 V	+ 12 V
GND	GND	GND	GND	GND

Required Mating Connector

A Molex Mini-Fit Jr model 5557 receptacle is required. At least three wire crimp terminals are required: 4.2 mm Pitch Mini-Fit Family Terminal-crimp, Female model 5556 or 44476. Either of these two terminals can be used.

Preventive Maintenance

Preventive maintenance for the multiple channel controller consists of cleaning various parts of the mainframe. The switch control unit and switches do not require preventive maintenance. Hewlett-Packard recommends a 12 month interval between cleaning. However, cleaning intervals are mostly dependent upon where the mainframe is used. The mainframe should be cleaned more often if it is used in a dusty, or very humid area.

To perform the preventive maintenance, refer to the mainframe, *HP E1301B, Service Manual*. The maintenance instructions are in the Operating Instructions chapter.

10

Accessory Documentation

This blank section is supplied as a storage place for smaller documents related to HP 85330A accessories. The *HP 85331A and HP 85332A User's Manual* is an example of documents that may be stored here.

A

Glossary

a1

The reference IF channel of the HP 8530A. This channel can be used as a phase lock reference or a test channel.

a2

The test IF channel of the HP 8530A. This channel can be used as a phase lock reference or a test channel.

AUT

Antenna Under Test

b1

One of three test channels of the HP 8530A.

b2

One of three test channels of the HP 8530A.

Channel

Each switch module has either two or four possible switch positions, or channels.

Controller

The mode the HP 85330 operates in when it is controlling other HP 85330A's. Refer to the "RUNTime:CONTRoller" command and Chapter 6, "Programming" for more information.

Direct Control

Direct control is where the host computer issues HP-IB commands and the HP 85330A executes them immediately. For example, the `ROUTE:CLOSE (port number) (switch address)` command causes the HP 85330A to immediately change switch states. Use of such commands is referred to as direct control.

Fast CW Modes

Refer to the glossary entry for "Fast Data Acquisition Modes."

Fast Data Acquisition Modes

Fast Data Acquisition modes (also called “Fast CW” modes) refer to a set of similar HP 8530A measurement modes where:

- All data processing except averaging is suspended to provide fastest possible measurement speed.
- All data is stored in a 100,000 point FIFO data buffer, which can be read by a computer controller.

As mentioned above, these modes are also referred to as the “Fast CW” modes. The term “Fast CW” is somewhat misleading, however, because with the proper equipment configuration these modes *can* be used in multiple-frequency applications.

There are several versions of the Fast Data Acquisition feature, but for PIN switch applications the recommended mode is the “Autoranged Data Collection” mode (FASAD). This mode accepts sudden changes in input power by autoranging. The changes in power can span the entire dynamic range of the receiver. Refer to the Automated Measurements chapter in the *HP 8530A User's Guide* for a full description of this mode, including an HP BASIC programming example.

Fast Source Control

Fast source control speeds up frequency switching speed in multiple-frequency measurements. It is only available in systems that use two sources. This mode uses TTL signals to increment RF and LO source frequency, providing faster frequency switching speeds than are possible under HP 8530A control. In the fast source control configuration, the system's computer must set up the sources with appropriate frequency settings, triggering mode, and so on. When automatic run-time measurement mode is engaged, the HP 85330A automatically increments the RF and LO source frequencies using TTL lines. More information is provided in Chapter 6, “Programming”. When being controlled by a computer, the SCPI language mode must be selected. This is shown in Figure 1-3 on page 1-5.

HP 85330A System

This term describes the following products, used together in a functional switch control system:

- HP 85330A multiple channel controller
- One or more HP 85331A or HP 85332A pin switches (with supplied SCUs)
- Attaching cables

Insertion Loss

A transmission measurement determines how much RF energy is lost as it passes through the device under test (DUT). Energy loss is measured in units called “insertion loss” and is measured in dB units. It is important to be aware of transmission losses in the system so you will not attribute them to the antenna or device under test.

For example: If you send 0 dBm down a cable with 10 dB of insertion loss, -10 dBm will come out the other end.

LO/IF Unit

Name for the HP 85309A LO/IF Distribution Unit.

Operating Characteristic

The term “operating characteristic” refers to performance that is based on design parameters, but is not actually measured.

Port

One of the two control ports on the back of the Multiple Channel Controller (PORT 1 and PORT 2). Each port provides independent control over one or more SCU/switch module pairs. In standard systems, one of the following configurations is used:

- Standard system with one SCU/switch module pair: The SCU can be connected to either port 1 or port 2.
- Standard system with two SCU/switch module pairs: One SCU is connected to port 1, and the other is connected to Port 2.

Ratio

The default type of measurement made with the HP 8530A is a ratioed measurement. Ratioed measurements divide the test signal input by the reference signal input. (For example, selecting b1/a1 would divide the test signal at b1 by the reference signal at a1.) A ratioed measurement provides common-mode rejection of errors caused by the transmitter or transmit antenna.

Receive Switch

Any switch set up on the receiver-side of the range. This is the switch that you have set up to select different antennas under test, or different polarity outputs from the same antenna, and so on.

Receiver

The HP 8530A. The HP 8530A receives the IF signal, digitizes it and processes the digital signals.

Receiver System

All of the instruments in the system that act as the RF downconverter and IF receiver.

Remote 1

The mode a HP 85330 operates in when it is being controlled by another HP 85330A in the Controller mode. Refer to “RUNTime: CONTroller” command and Chapter 6, “Programming” for more information.

Remote 2

The mode a HP 85330 operates in when it is being controlled by another HP 85330A in the Controller mode. Refer to “RUNTime: CONTroller” command and Chapter 6, “Programming” for more information.

Return Loss

Reflection measurements determine how much RF energy bounces off of a cable connector or the input of a device. This reflected energy is measured in “return loss” units. Reflected energy travels back toward the RF source.

For example. If you send a 0 dBm signal into a cable with 14 dB of return loss, a lower-level signal (–14 dBm) will reflect off the input of the cable and travel back toward the source. A low return loss value is bad because it shows that too much power is being reflected back out of the system. This indicates a bad connection somewhere in the system.

Run-Time

Refer to “Run-Time Control Mode.”

Run-Time Control Mode

This is an automatic mode where the HP 85330A can be preprogrammed to run a measurement. Using HP-IB commands, the HP 85330A must setup prior to run-time. Then, an HP-IB command is issued to pass run-time control to the HP 85330A. Refer to Chapter 6, “Programming” for details.

SCU

Refer to “Switch Control Unit.”

SCU Address

Each Switch Control Unit can be assigned a unique address called an SCU address. When commands are sent to the SCUs, they only affect SCUs with the specified SCU address. SCU addresses are set using DIP switches inside the SCU, and can be set to 0, 1, 2, or 3. The factory default setting is 0. If you daisy-chain several SCUs together they may use the same SCU address.

Standard System

A “standard system” uses one HP 85330A with *one or two* switch control units, each with a two-throw or four-throw switch module. Remember that HP 85330A PORT 1 and PORT 2 are addressed independently. So:

- If you have two SCUs, both can use the default SCU address (0).
- You can use the default channel numbers (1 through 4) for *both* switch modules. Since each SCU is on a different port, and each port is addressed independently, there is no channel number conflict.

Switch Control Unit

Each switch control unit (SCU) provides bias and switch control of one switch module. Each SCU contains a decoder board, which allows you to set the SCU to a unique SCU address from 0 to 3 using DIP switches. The factory default setting is 0.

Switch Address

This is the complete software address for a specific switch. It is simply a concatenation of the SCU address (0, 1, 2, or 3) with the channel number (usually 1, 2, 3, or 4, but possibly a number up to 64).

Examples:

@2 = SCU address is 0 (and need not be specified), and channel 2 is selected.

@103 = SCU address 1 and channel 3 selected (usually a custom system).

@232 = SCU address is 2 and channel 32 is selected (custom systems only).

Switch Module

The single-pole two-throw (SP2T) or single-pole four-throw (SP4T) RF switch. The switch module is controlled by a Switch Control Unit.

Typical

When a specification is noted as being typical it means that most units exhibit the stated performance, but not all. For this reason the specification is not guaranteed by Hewlett-Packard. Generally, typical specifications are provided for non-critical performance categories.

Index

A

- adjustments, 9-23
 - negative edge operation for event trigger, 9-23
 - positive edge operation for event trigger, 9-23
- angle scan measurements using TTL triggering, 6-12
- automated operation, 4-3
- AUX 1, 4-13
- AUX 2, 4-13
- AUX POWER IN, 4-14

C

- changing TTL state of AUX 1 and AUX 2, 5-6
- channel, 6-2
- chart of run-time measurement sequence, 6-16
- choosing a measurement configuration, 6-3
- cleaning mainframe, 9-26
- closing switch manually, 5-5
- command syntax, 6-1
- compatible instruments, 4-15
- compatible LO sources, 4-15
- compatible RF sources, 4-15
- CONTRol, 7-11
- control
 - setting a desired switch state, 6-9
- CONTROLLER, 7-14
- COUNT, 7-15, 7-18
- custom option number, 5-9
- CW measurements, 6-4

D

- definition of
 - a1, A-11
 - a2, A-11
 - AUT, A-11
 - b1, A-11
 - b2, A-11
- channel, A-11
- controller, A-11
- direct control, A-11
- fast CW modes, A-11
- HP 85330A system, A-12
- insertion loss, A-13
- LO/IF unit, A-13
- operating characteristic, A-13
- port, A-13
- ratio, A-13
- receive switch, A-13
- receiver, A-13

- remote 1, A-14
- remote 2, A-14
- return loss, A-14
- run-time, A-14
- run-time control mode, A-14
- SCU, A-14
- SCU address, A-14
- standard system, A-15
- switch address, A-15
- switch control unit, A-15
- switch module, A-15
- typical, A-15
- definition of terms, 6-2
- DELay, 7-21
- definition of
 - fast source control, A-12
- direct control, 6-1
- downloadable driver, 4-5
- downloadable driver, for HP 85330A, loading, 1-6
- driver(downloadable)
 - HP 85330A, 1-6
- dual source multiple frequency measurements, 6-7

E

- electrostatic damage, 1-2
- environmental limits, 4-9
- equipment required, 4-5
- error messages, 5-7, 6-31
- EVENT, 7-15, 7-16, 7-24
- EVENT TRIG, 4-12
- event trigger
 - changing to positive or negative edge trigger, 9-23
 - negative edge operation, 1-9
 - positive edge operation, 1-9

F

- fast data acquisition modes, A-12
- fast source control, 6-8
- frequency response measurements using IMM triggering, 6-12
- front panel features, 4-11, 5-2
- front panel operation, 5-2

G

- general information, 4-1

H

- HP 8530A source control, 6-7
- HP 85330A
 - HP-IB address, 1-8
- HP 85330A characteristics, 4-9
- HP 85330A error messages, 6-31
- HP 85330A HP-IB address, 5-4
- HP 85331A SP2T pin switch, 4-7
- HP 85332A SP4T PIN switch, 4-7
- HP 85383A remote trigger cable, 4-6
- HP 85383B expansion cable, 4-6
- HP 85394A switch driver cable, 4-6
- HP-IB address, 1-8
 - adjustments, 9-24
- HP-IB commands
 - ROUT
 - DELaY, 7-12
 - RUNTime, 7-13, 7-15, 7-16, 7-17, 7-18, 7-19, 7-20, 7-21, 7-22, 7-23, 7-24, 7-25, 7-26, 7-27
 - CONTRoller, 7-14
- HP-IB softkey, 5-4

I

- IMM, 7-17
- IMM triggering mode, 7-16
- in case of difficulty, 8-11
- INITiate, 7-17
- installation
 - HP 85330A
 - fast source control, 1-2
- installing
 - HP 85330A, 1-2
 - choosing configuration, 1-2

L

- loading
 - HP 85330A
 - downloadable driver, 1-6
- local control cable, 4-5

M

- manual operation, 5-1
- MEAS BUSY, 4-12
- measurement sequence of run-time mode, 6-14
 - multiple controllers, 6-18
- menu keys, 5-2
- more key, 5-2
- multiple frequency measurements, HP 85309A based, 6-7

N

- negative-edge TTL trigger operation, 4-12

- number of angular increments for run-time mode, 6-12

O

- operators check, 3-1
- ordering information, 9-14

P

- performance verification, 2-1
 - equipment, 2-2
- pin switch modules, 4-5
- preventive maintenance, 9-26
- product description, 4-2
- programming, 6-1
- programming commands, 7-19
 - ROUT, 7-11
 - ROUTe
 - DELaY, 7-12
 - RUNTime, 7-13, 7-14, 7-15, 7-16, 7-17, 7-18, 7-20, 7-21, 7-22, 7-23, 7-24, 7-25, 7-26, 7-27
- programming operations summary, 6-1

R

- RCVR READY, 4-13
- RCVR TRIG, 4-12
- rear panel features, 4-12
- RECeiver, 7-25
- recent error messages, 5-7
- recommended test equipment, 9-8
- REMOte, 7-26
- REMOTE 1 and 2, 4-14
- replaceable parts, 9-14
- required equipment, 4-5
- RUNTime, 7-19
 - EVENT
 - COUNT, 7-15
 - EVENT
 - TRIGger, 7-16
 - INITiate
 - IMM, 7-17
 - SOURce
 - COPUNt, 7-18
 - SOURCE1
 - TRIGger, 7-19
 - SOURCE2
 - TRIGger, 7-20
 - SWITCh
 - DELaY, 7-21
 - SCAN, 7-22
 - TRIGger, 7-23
 - TIMEout
 - EVENT, 7-24
 - RECeiver, 7-25
 - SOURce, 7-27

- run-time control
 - flow chart of measurement sequence, 6-16
 - list of switch states, 6-12
 - measurement sequence, 6-14
 - multiple controllers, 6-18
 - number of angular increments (events), 6-12
 - number of frequency points, 6-12
 - starting, 6-14
 - switch settling time, 6-13
 - triggering, 6-12
 - TTL trigger timeouts, 6-13
 - tutorial, 6-14
 - multiple controllers, 6-18
- run-time control mode, 6-12

S

- SCAN, 7-22
- SCU address, 6-2
- selecting a channel, 5-5
- sending trigger pulses manually, 5-10
- service, 9-9
- service assembly/disassembly, 9-19
- service functions, 5-10
- single source HP 8511A/B based, 6-5
- single source multiple frequency, 6-5
- softkey map, 5-3
- SOURce, 7-18, 7-19, 7-20, 7-27
- source control, fast, 6-8
- SOURCE1, 7-19
- SOURCE2, 7-20
- SRC 1
 - READY, 4-13
 - TRIG, 4-13
- SRC 2
 - READY, 4-13
 - TRIG, 4-13
- static electricity, 1-2
- supplied equipment and software, 4-8
- SWITCh, 7-21, 7-22, 7-23
- switch decoding, 4-4
- SWITCH PORT 1 and 2, 4-14
- switch settling time for run-time mode, 6-13
- switch states for run-time mode, 6-12
- switching to AUX POWER IN bias, 9-25
- switching to internal bias, 9-25

T

- testing the HP 85330A for proper operation, 3-1
- TIMEout, 7-24, 7-25, 7-26, 7-27
- timeouts, 6-13
- TRIGger, 7-16, 7-19, 7-20, 7-23
- troubleshooting, 9-10
- TTL mode, 7-16
- TTL source control, 6-8
- TTL trigger timeouts, 6-13
- TTL triggering mode, 7-16

U

- using direct control, 6-9
- utility keys, 5-2

V

- viewing the revision of downloaded driver, 5-8

